

Luxman

SUPER AUDIO CD PLAYER

D-07X

Owner's Manual

Contents

Precautions	1
Features of This Unit.....	3
Compatible Discs	7
Before Use	8
Names and Functions.....	11
Connections	19
How to Play Back Discs	23
Stop/pause the Playback.....	25
Skip/Fast-forward/Rewind	27
Direct search/repeat playback	29
Program Playback	31
Random playback/disc information/zoom	33
Detailed Settings	35
Block Diagram	41
Specifications	42
Before Asking for Repair Service.....	43

Precautions

DO NOT move this unit during playback.

During playback, the disc is rotating at high speed. Do not try to lift or move this unit as the disc may be damaged. Otherwise, the disc may be damaged.

When moving this unit

You must remove the disc and close the disc tray when moving this unit. Then, press the OPERATION button, and after “-STANDBY-” on the display window turns off, unplug the power cord from the AC outlet. If the unit is moved with a disc remaining inside, this can cause a malfunction.

Installation location

Install this unit in a location where good ventilation and heat radiation are assured.

Especially, installation of this unit where direct sunlight is present, where the temperature rises excessively high such as close to a heater, or where it is humid or dusty may cause a malfunction even if heat is efficiently released.

Therefore, do not install this unit in such places.

Note:

For heat dispersal, do not install this equipment in a confined space such as a book shelf or similar unit.

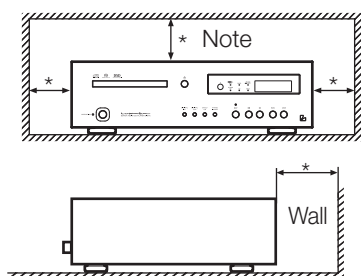

- Choose a stable place near the stereo system that is to be used in combination with this unit.
- Do not install this unit near a television or color monitor. Keep this unit away from magnetically sensitive devices such as cassette decks.
- Install this unit on a level surface.

Avoid the following locations for installation

- Locations exposed to direct sunlight
- Locations subject to humidity and which lack ventilation
- Locations that are extremely hot or cold
- Locations which experience strong vibration
- Dusty locations
- Locations subject to oil, steam, and heat (such as kitchens)

Do not cover.

Do not cover or place any items or other units on top of this unit.

Avoid sources of heat

Do not place this unit on top of any device as an amplifier that may emit heat. If the unit is installed on a rack install the unit below the rack where the amplifier is installed so as to avoid heat emission from the amplifier and other audio devices.

Notice when this unit is installed in a rack with glass doors

While the glass doors are closed, do not open the disc tray by pressing the open/close (▲) button of the remote control. Disc tray performance will be blocked, and that may result in a malfunction.

Notice when this unit is installed in a rack with glass doors

While the glass doors are closed, do not open the disc tray by pressing the open/close (▲) button of the remote control. Disc tray performance will be blocked, and that may result in a malfunction.

Turn off this unit when it is not used.

Depending on the condition of radio waves emitted during television broadcasting, interference fringes may appear on the television monitor, but that is not a malfunction. In such a case, turn off the unit. There may also be a case where noises are heard on the radio due to radio wave interference.

Condensation

In winter, be careful when carrying this unit from a cold place to a warm place or if the room temperature where this unit is installed is suddenly raised by a heater. The unit interior operating mechanism and lens may collect condensation. Under such conditions, this unit will not work normally and playback may be impossible. This depends on the amount of condensation. If the unit is turned on and left untouched for one to two hours, the operating temperature of this unit will dry any condensation.

Condensation can occur even in summer if this unit is directly exposed to cool air from an air conditioner. In such a case, the installation location should be changed.

Batteries

Warning: Batteries used for the remote control shall not be exposed to excessive heat such as sunshine, fire or the like.

How to handle discs

- Do not use any deficient disc (cracked, warped, etc.).
- Do not damage the signal surface of the disc or make it dirty.
- Do not place paper or a stickers on the disc. Such awkward handling can warp the disc and playback may become impossible. In many cases, rental discs carry labels and glue may leak from under the label. Before use, check that the disc is free from leaking glue or the like.
- Do not play two discs in a stack.
- Some discs with a printable surface, so-called “printable CD-Rs”, easily stick to the mechanism which holds the CD during playback. Please do not use such discs as it may become impossible to eject the disc or cause a failure of the unit.

How to store discs

- Always put your discs in a case. Store them vertically where high temperature, high humidity, and direct exposure to sunlight are not prevalent. Places with extremely low temperature should also be avoided.
- Read the caution notes carefully that are attached to discs.

Disc cleaning

- If a disc is dirty from fingerprints or dust, this may affect sound quality. Lightly wipe the disc with soft cloth, from the inside to outer edge. (Don't wipe it with a circular motion.)
- Do not use a volatile chemicals such as benzine or thinners. Record spray, anti-static agents, and other such cleaners must not be used either.
- If a disc seems to be very dirty, dip soft cloth in water, wring it well, wipe away the dirt and finally remove the moisture with dry cloth.

Specifically designed discs

This unit cannot play discs with specifically designed shapes such as heart-shaped or hexagonal discs. Never use such discs as they can cause malfunctions.

Lens cleaning

If the lens gets dusty, discs may skip during playback. Please read “After-sales Services and Quality Assurance” and ask us for cleaning. Do not use any commercial cleaning discs available because they may damage the lens.

Notice on handling optical digital cables

- Do not fold the cables. For storage, wind each cable into a coil about 15 cm in diameter or larger.
- For connection, insert the cable connectors firmly into the terminals of this unit and the other device.
- Only use 3 meter long cables or shorter.
- When the cable connectors get dusty, wipe the dust away with a dry soft cloth before inserting into the terminals.

Cleaning

- Usually, wipe the unit with a dry soft cloth. When the dirt is hard to remove, dip a soft cloth in detergent diluted 5 or 6 times with water, wring it well, and remove contaminants. Then, remove the moisture with dry cloth.
- Do not use a solvent like alcohol, benzine, thinner, or pesticide because such a substance can damage the exterior. In addition, do not let this unit contact rubber or plastic foam for a long time. That may damage the cabinet surface of the unit.
- Before cleaning, unplug the power cable from the AC outlet.

Safety caution

Caution

This unit is heavy. Be careful when unpacking, carrying, and installation.

Features of This Unit — 2-channel-specific Super Audio CD/CD Compatible Player

LxDTM improved — Luxman original Disc Transport Mechanism —

The side frame that is firmly integrated into the transport mechanism has a highly rigid structure, which extends from the front and rear, and also adopts SSB (Stabilized Support Block).

The aluminum die-cast disc tray also helps to control vibration and resonance. The disc tray opens and closes via a QLL (Quiet Linear Loader), ensuring quiet, smooth operation.

Analog circuitry

This unit has an independent monaural operational D/A converter on the right and left sides. Then, the high-quality discrete buffer circuit with fully balanced configuration reduces the impedance in the differential output of these converters.

This circuit drives the integrated amplifier and control amplifier that are connected to the next stage in a powerful manner.

BD34301EKV manufactured by ROHM Co., Ltd. equipped

This unit features ROHM's BD34301EKV DAC chips in independent left and right dual monaural configuration.

USB input 768kHz/32-bit supported

The B-type USB input terminal makes it possible to input digital audio signals from a PC or Mac with a sampling frequency of up to 768kHz and 32-bit quantization.

USB input supports DSD

DSD formatted data can be read from PC or Mac, or the like. Sampling frequencies of 2.8MHz/5.6MHz/11.2MHz/22.4MHz are supported.

Asynchronous communication supported

The USB input's low jitter characteristics have been achieved by a dedicated DSP chip using asynchronous communication and PLL.

MQA (Master Quality Authenticated)

MQA is an award-winning British technology that delivers the sound of the original master recording.

The master MQA file is fully authenticated and is small enough to stream or download.

Visit www.mqa.co.uk for further information.

This unit includes MQA technology, which enables you to playback MQA audio files and streams from all digital inputs, delivering the sound of the original master recording. The product also supports MQA-CD playback. The built-in MQA decoder will automatically restore the high-resolution signal heard in the studio and confirm it, using the authentication signature.

Ultra-low phase noise crystal oscillator

This unit uses an extremely low noise oscillator in the vicinity of the oscillating frequency.

This oscillator provides accurate clocking with less jitter.

Disc layer switchover function

By pressing a switch on the main unit or remote control, the listener can alternate between the CD layer and the HD layer of a Hybrid Super Audio CD.

Zoom function

When the ZOOM button is pressed on the remote control, enlarged track number and time information can be displayed.

4 playback modes

Playback mode can be selected from regular, programmed, random, and repeat playback modes.

*1 Mac and macOS are trademarks of Apple Inc., registered in the U.S. and other countries.

*2 Windows is a registered trademark of Microsoft Corporation in the United States and/or other countries.

*3 DSD is a trademark.

*4 Sound Wave Logo is a registered trade mark of MQA Limited. ©2018

*5 MQA is a registered trade mark of MQA Limited. ©2018

*6 MQA-CD is a registered trade mark of MQA Limited. ©2017

*7 The described company names and product names are trademarks or registered trademarks of each company.

Features of This Unit

Digital input terminals

This unit is equipped with a coaxial input terminal and an optical input terminal. It is compatible with S/PDIF formatted signals between 44.1 kHz and 192 kHz.

Low jitter digital inputs (S/PDIF) have been achieved by using Burr-Brown PCM9211 PLL chips.

Digital audio signals from other audio devices are played back with significantly improved audio quality.

DD converter function

Signals encoded at 192 kHz/24 bit or less, including USB input, are digitally reproduced over S/PDIF.

Last memory function

Built-in flash memory can memorize settings such as digital input, Super Audio CD/CD, digital filter, etc.

Dimmer function

The display brightness can be adjusted with 4 brightness levels.

Digital output OFF

The digital audio output can be deactivated to improve the quality of the analog audio output.

Analog output terminals

The terminals consist of a gold-plated RCA output terminal and an XLR terminal manufactured by Neutrik.

Analog output phase switching

Both balanced output and unbalanced output are phase switchable.

Original technologies

Our traditional, non-angled circuitry, OFC internal wiring, and original custom-made components are used throughout the unit.

Cast-iron insulators

For stability and support, this product features cast iron feet with vibration reducing density gradient.

Remote control (RD-29)

The remote control is encased in aluminum. Tactile switches will satisfy users with a light key touch.

Highly stable power supply

The unit's highly stable power supply circuitry features a large capacity OI-core-type power transformer with 9 custom designed 3,300 μ F blocking capacitors.

Schottky barrier diodes

By using Schottky diodes, manufactured by KYOCERA Corporation, this unit achieves very high DC conversion efficiency in the power rectifier circuitry and much less switching noise.

LUXMAN's original OFC wiring

Our original OFC cable, with non-plated core wire, is used for internal wiring to achieve smooth signal transmission.

Compatible Discs

Types of discs that can be played

The following marks are printed on disc labels, packages, or CD jackets.

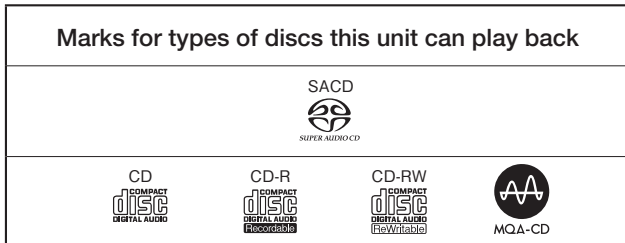

This unit can play back 8 cm CDs without using an adapter. Do not use an adapter for 8 cm CDs.

- CD-R/CD-RW discs that have been written by a recorder or PC may not be played back (due to characteristics of discs, scratches, dirt on discs, dirt on the lens of the unit, condensation, etc.).
- Discs written by a PC may not be played back depending on the application settings or environment. Write the discs in a proper format. (Refer to the distributor of application for details.)
- Time information may not be displayed when an unfinalized CD-R/CD-RW disc is played back.
- Refer to the precautions for discs for details on how to handle CD-R/CD-R discs.

Super Audio CD

— 3 types of disks —

• Single-layer CD

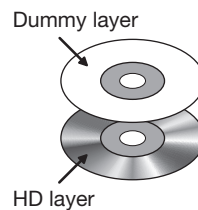

This is a disc which has a single Super Audio CD layer.

• Dual-layer CD

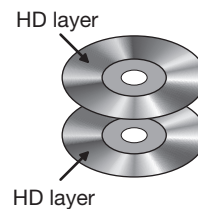

This is a CD which has a dual Super Audio CD layer that supports long recording times.

• Hybrid-layer CD

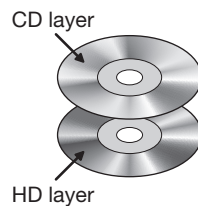

This is a CD which has both a standard CD layer and Super Audio CD layer. When the disc is played back on a Super Audio CD player, it is possible to enjoy improved sounds quality from the HD layer. When the disc is played back on an existing CD player, it is only possible to play back sounds from the CD layer.

HD layer: Super Audio CD layer
CD layer: Existing CD layer

HD layer provides the following:

- 2-channel stereo area
- Multi-channel area
- Extra data area
(For future expansion)

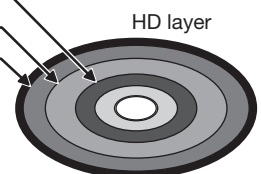

Comparison of Super Audio CDs with CDs

Item	Super Audio CD	CD
Disc diameter (cm)	12	12
Disc thickness (mm)	1.2	1.2
Coding method	1-bit direct stream digital (DSD)	16-bit linear PCM
Sampling frequency	2.8224 MHz (64 times to CDs)	44.1 kHz
Maximum recordable time	109 minutes for 2ch only. 60 to 70 minutes for 2-channel stereo area + multi-channel area * ¹	74 minutes
Number of channels	2, 3, 3.1, 4, 4.1, 5, 5.1	2
Maximum number of tracks	255	99
Maximum number of indexes	255	99
Playback frequency range	DC to 100 kHz	5 to 20 kHz
Dynamic range * ²	120 dB or more (audible range)	96 dB

*¹ This is the maximum recordable time for a single-layer CD. Depending on the compression rate of DST (Direct Stream Transfer)*³, the maximum recordable time may vary.

*² Theoretical value

*³ Lossless compression method that applies a variable bit rate for DSD signals. The method has been developed, focused on the DSD signal characteristics.

Before Use

Check the accessories

Whilst unpacking, check if the following accessories are included.

- Power cable
- Remote control (RD-29)

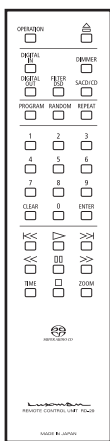

- Two “AAA” batteries

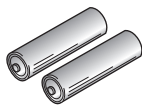

- Safety cautions
- Owner’s Manual (This document)

How to Use the Remote Control

Insert batteries into the remote control

1. Remove the battery cover on the rear of the remote control. Put your finger on the battery cover claw and slide the cover downward to remove the cover.
2. Put 2 AAA batteries in the battery case as shown in the illustration on the battery case paying attention to the battery polarity ((+) and (-)).
3. In the reverse order of battery cover removal, put the battery cover back to the opening of the remote control and slide the cover upward until it clicks.

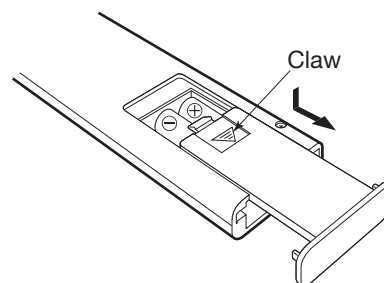

- Do not use a combination of new and old batteries together.
- There may be a case in which the voltages are different between two batteries even though they are the same size. Do not use batteries of different types together.
- If the remote control is not used for a long time (more than 1 month), the batteries shall be removed from the case. If battery fluid is leaking, wipe away the liquid from the case before inserting new batteries.
- To discard exhausted batteries, follow the instructions from your local authority.

Remote control's range

To use the remote control, aim it at the remote control infrared receiver on the front panel of main unit. The effective distance is approx. 5 m from the main unit and at 30 ° to either side of the remote control infrared receiver.

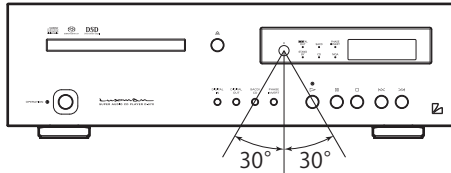

Effective distance:
approx. 5 meters

Do not expose the remote control infrared receiver to direct sunlight or strong light sources. That may cause a malfunction.

Names and Functions

Front panel

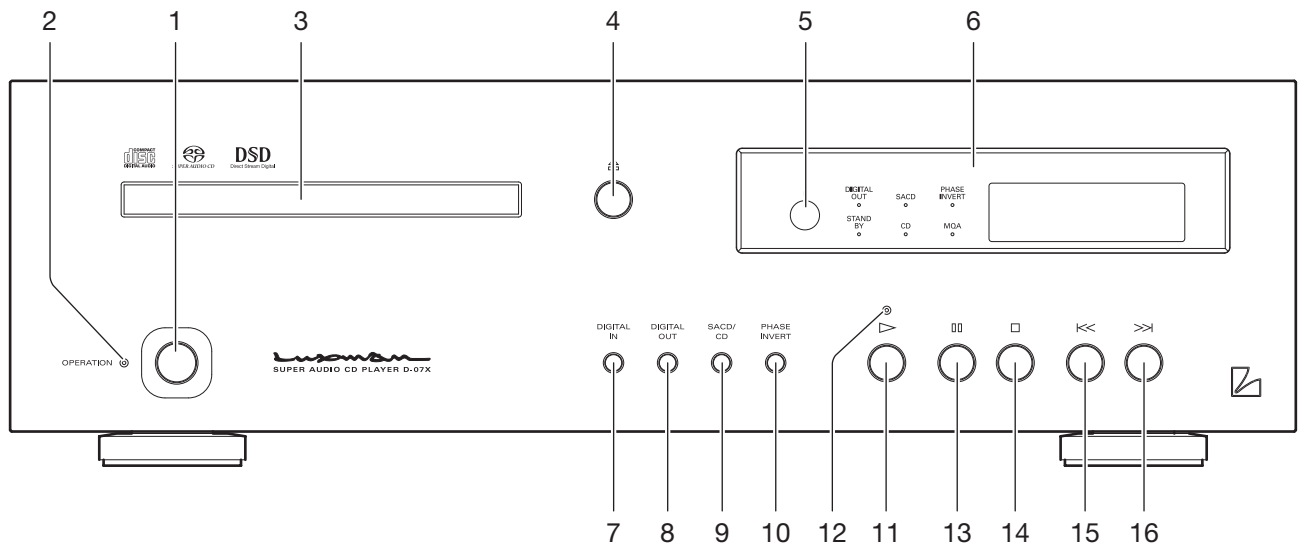

1. Operation button (OPERATION)

Turns this unit from the standby state to operation state. When the main power switch on the rear panel is turned ON/STANDBY to set this unit to the standby state and this switch is turned on, this unit is set to the operation state.

2. Operation indicator (OPERATION)

Blinks during warm-up when the operation button is turned on and lights up when the operation state is activated afterward.

3. Disc tray

When inserting or removing a disc, this tray is opened or closed by pressing the open/close button (4).

4. Open/close button (4)

Opens or closes the disc tray.

5. Remote control infrared receiver (R)

Receives signals from the accessory remote control.

6. Display window

Displays the operation status of this unit. This display is composed of 6 indicators and display tube.

7. Digital input selection button (DIGITAL IN)

Press this button when using the unit as a D/A converter. Switchover is performed among coaxial, optical, USB, and internal player.

8. Digital output selection button (DIGITAL OUT)

Press this button to turn the digital audio output on or off. Each time the button is pressed, the output can be turned on or off. The digital audio output cannot be used when playing back the HD layer of Super Audio CD.

9. Super Audio CD/CD selection button (SACD/CD)

When playing back a Hybrid Super Audio CD, this button should be pressed to switch between the CD playback layer and the HD (or SACD) layer.

10. Phase invert button (PHASE INVERT)

The phase of the analog output on the rear panel can be inverted for both the balanced output and unbalanced output. This setting is stored on the flash memory even when the power is turned off.

Every time this button is pressed, the balanced phase changes as follows: NORMAL → INVERT → NORMAL → INVERT → ...

[Phase Normal]

1. GROUND
2. COLD (-)
3. HOT (+)

[Phase Inverted]

1. GROUND
2. HOT (+)
3. COLD (-)

11. Play button (▶)

Plays back a disc.

12. Play indicator

Lights up while a disc is being played back. Blinks while playback is being paused.

13. Pause button (⏸)

When this button is pressed during playback, the playback stops. When this button is pressed again, the playback starts again. During pause, the play indicator blinks.

14. Stop button (⏹)

Stops playback.

15. Previous button (⏮)

When this button is pressed once, the playback returns to the beginning of current track. When this button is pressed twice, playback returns to the beginning of the previous track.

16. Next button (⏭)

When this button is pressed, the playback jumps to the beginning of next track.

Names and Functions

Display window

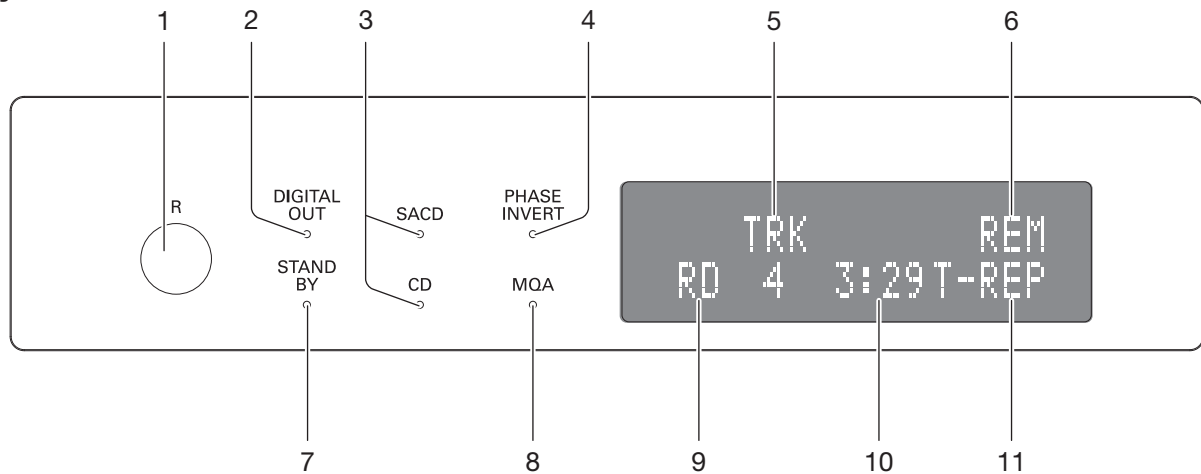

1. Remote control infrared receiver (R)

Receives the infrared signals from the remote control.

2. Digital output indicator (DIGITAL OUT)

Lights up when the digital audio output is ON.

This indicator does not light up when playing back the HD layer of Super Audio CD because the digital audio signal cannot be output.

3. Super Audio CD/CD indicator (SACD/CD)

SACD indicator lights up when playing back the HD (or SACD) layer of Hybrid Super Audio CD

CD indicator lights up when playing back the CD layer of Hybrid Super Audio CD.

4. Phase invert indicator (PHASE INVERT)

Lights up when the analog output phase is inverted, which is caused by pressing the phase invert selector.

[Off (Phase Normal)]

1. GROUND
2. COLD (-)
3. HOT (+)

[On (Phase Inverted)]

1. GROUND
2. HOT (+)
3. COLD (-)

5. Track number (TRK)

"TRK" is displayed above, and the track number is displayed below during playback.

6. Time display mode

The display shows different playback time modes. "REM" is displayed indicating the remaining time of the current track. "T-REM" is displayed indicating the total remaining time of disc. This display area does not light up when showing the elapsed time of a track.

7. Standby indicator (STANDBY)

Lights up when this unit is in the standby state.

8. MQA indicator (MQA)

Lights up while an MQA-CD, an MQA file or stream is being played back

[Off]

It is not an MQA source

[Green Light]

It is indicating that the unit is decoding and playing an MQA stream or file and denotes provenance to ensure that the sound is identical to that of the source material.

[Blue Light]

It is indicating the unit is playing an MQA Studio file, which has either been approved in the studio by the artist/producer or has been verified by the copyright owner.

[Magenta Light]

It confirms that the product is receiving an MQA stream or file. This delivers the final unfold of the MQA file and displays the original sample rate.

9. Playback mode

“RD” is displayed during random playback. “PG” is displayed during program playback. This display area does not light up during regular playback.

10. Time

Displays the elapsed time of current track, remaining time of current track, or remaining time of disc. Time display is switched over according to time display mode.

11. Repeat mode

Displays the mode for repeat playback. There are two types of repeat playback: track repeat (T-REP) and all repeat (A-REP).

Names and Functions

Remote control

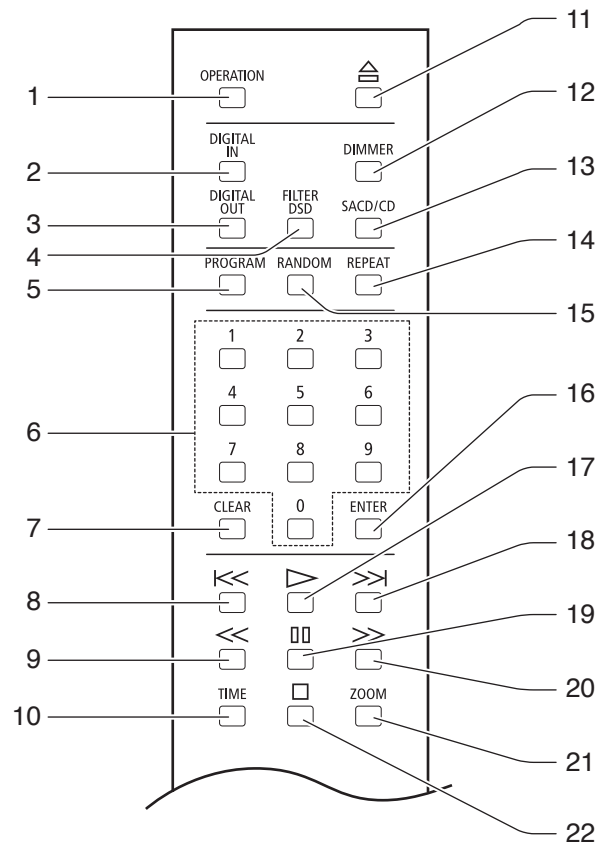

1. Operation button (OPERATION)

Turns this unit to the operating state after turning off the standby indicator at the standby state. Pressing this button again at the operating state turns the unit to the standby state.

2. Digital input selection button (DIGITAL IN)

Press this button when using the unit as a D/A converter. Switchover is performed among coaxial, optical, USB, and internal player.

3. Digital output selection button (DIGITAL OUT)

Turns on/off the digital output (COAX/OPT).

4. Analog FIR filter selection button (FILTER DSD)

This button changes the analog FIR filter while a Super Audio CD (HD layer) or a DSD file is being played back.

Select a filter depending on your taste. The sound quality can be changed by engaging one of 2 different filters, D-1 and D-2.

Pressing this button displays the current setting data (D-1 or D-2) on the display window.

Pressing this button again while the filter selection is displayed displays the next filter selection.

Pressing the enter button (ENTER) while the setting data is displayed confirms the filter setting.

If the enter button is not pressed, the filter will not be engaged.

5. Program button (PROGRAM)

Programs the track numbers to play back in a desired order.

6. Numeric keys (1, 2, 3, 4, 5, 6, 7, 8, 9, 0)

These keys are pressed to specify the track numbers for direct search or playback order programming.

7. Clear button (CLEAR)

Cancels the program settings.

8. Previous button (⏮)

Pushing this button returns playback to the beginning of the track. When this button is pressed twice, playback returns to the beginning of the previous track.

9. Rewind button (⏪)

When this button is pressed during playback, the track will rewind until the button is released.

10. Time display button (TIME)

This button adjusts the time display mode between the elapsed time of the current track, remaining time of the current track, or remaining time of disc.

11. Open/close button (⏏)

Opens or closes the disc tray.

12. Dimmer button (DIMMER)

Adjusts the brightness of the main unit display. The brightness can be adjusted in 4 steps from off, through two dim levels, to normal.

13. Super Audio CD/CD selection button (SACD/CD)

When playing back a Hybrid Super Audio CD, this button is pressed to switch playback between the HD (or SACD) layer and the CD layer.

14. Repeat button (REPEAT)

Pushing this button will enable repeat playback of the selected track or the whole disc. There are two types of repeat playback: track repeat (T-REP) and all repeat (A-REP).

15. Random button (RANDOM)

This button is pressed to perform random playback.

16. Enter button (ENTER)

Executes the set or selected items.

17. Play button (▶)

Plays back a disc.

18. Next button (⏭)

When this button is pressed, the playback jumps to the beginning of next track.

19. Pause button (⏸)

When this button is pressed during playback, the playback stops. When this button is pressed again, the playback starts again. During pause, the play indicator blinks.

20. Fast-forward button (⏩)

When this button is pressed during playback, the track will be fast-forwarded until the button is released.

21. Zoom button (ZOOM)

When this button is pressed during playback, the track number and time are displayed in an enlarged manner.

22. Stop button (⏹)

Stops playback.

Names and Functions

Rear panel

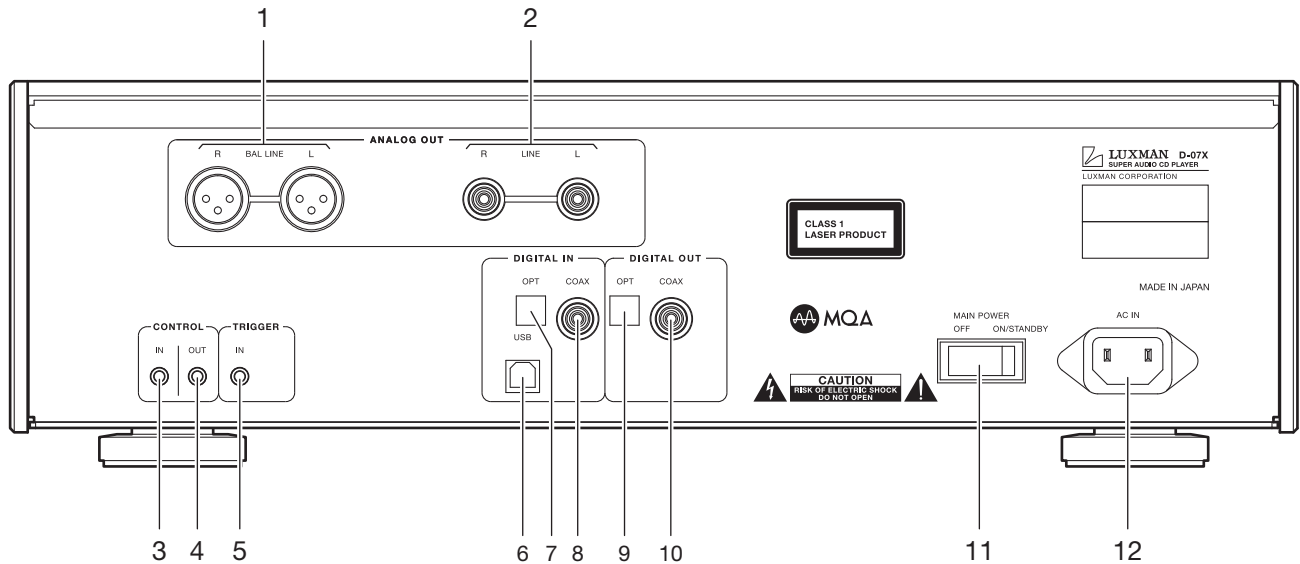

1. Balanced analog output terminals (BAL LINE)

Use these XLR output terminals to output balanced audio signals from this unit.

Connect these terminals to the balanced inputs of a unit such as a preamplifier using balanced XLR cables.

The output phase can be switched with the analog output phase selection button (PHASE INVERT) on the front panel. The following table shows the unit's XLR output terminals pin configuration:

[Phase Normal]

1. GROUND
2. COLD (-)
3. HOT (+)

[Phase Inverted]

1. GROUND
2. HOT (+)
3. COLD (-)

2. Unbalanced analog output terminals (LINE)

The RCA output terminals to provide unbalanced playback signals of this unit

Connect these terminals to the unbalanced inputs of a unit such as an integrated amplifier with a RCA cable.

The output phase can be switched with the analog output phase selection button (PHASE INVERT) on the front panel.

3. Control input terminal (CONTROL IN)

Connects a LUXMAN's device with a control output terminal using a commercially available 3.5-mm monaural mini-jack cable. This connection enables the infrared receiver circuit of the connected device to receive signals from the remote control supplied with this unit and the remote control to operate the device, too. (The infrared receiver of this unit will not function.)

4. Control output terminal (CONTROL OUT)

Connects a LUXMAN's device with a control input terminal using a commercially available 3.5-mm monaural mini-jack cable. This connection enables the infrared receiver of this unit to receive signals from the remote control of the connected device and the remote control to operate this unit, too. (The infrared receiver of the device whose input is connected will not function.)

5. Trigger input terminal (TRIGGER IN)

Trigger input terminal to be connected to a control amplifier, power amplifier and other devices that have a trigger output terminal. If the main power button is set to ON/STANDBY and this unit is turned to standby, this unit can be turned to operating or standby in conjunction with the operation button of a connected device. When the main power button is set to OFF, this unit does not operate in conjunction with other devices.

6. USB digital input terminal (USB)

Use this USB (B-type) input terminal digital input signals from a PC or Mac using a USB cable. The terminal supports the following signals.

- PCM signal

Sampling frequency: 44.1 kHz, 48 kHz, 88.2 kHz,
96 kHz, 176.4 kHz, 192 kHz,
352.8 kHz, 384 kHz,
705.6 kHz, 768 kHz

Quantization bit rate: 16-bit, 24-bit, 32-bit

- DSD signal

Sampling frequency: 2.8 MHz, 5.6 MHz,
11.2 MHz, 22.4 MHz

Quantization bit rate: 1-bit

Before connecting this unit to a PC or Mac the dedicated driver software needs to be downloaded from LUXMAN website and installed.

Refer to "Driver Installation Manual" on the LUXMAN website for detailed information.

Caution:

Connection between a PC or Mac and this unit using a USB cable should not be performed before the installation of the dedicated driver software is completed. Failure to observe this may cause a malfunction.

7. Optical digital input terminal (OPT)

When using this unit as a D/A converter, transmit digital signals from a CD player or the like that has a digital output terminal to this unit using an optical digital cable.

The terminal supports the following PCM signals.

Sampling frequency: 44.1 kHz, 48 kHz, 88.2 kHz,
96 kHz, 176.4 kHz, 192 kHz

Quantization bit rate: 16-bit, 20-bit, 24-bit

This is a shutter-type optical terminal. Direct the cable connector correctly when inserting the cable into the terminal. If the cable connector is inserted forcibly in the wrong direction, the terminal may be deformed and the shutter may not be able to close even after disconnecting the cable.

8. Coaxial digital input terminal (COAX)

When using this unit as a D/A converter, connect a CD player or the like that has a digital output terminal to this unit using a coaxial digital cable.

The terminal supports the following PCM signals.

Sampling frequency: 44.1 kHz, 48 kHz, 88.2 kHz,
96 kHz, 176.4 kHz, 192 kHz

Quantization bit rate: 16-bit, 20-bit, 24-bit

9. Optical digital output terminal (OPT)

Connect this terminal to a device such as a D/A converter or an amplifier that has a digital input terminal using an optical digital cable. When a Super Audio CD (HD layer selected) or a DSD file is played back, a digital audio output cannot be not provided. In addition, when PCM data of 352.8 kHz, 384 kHz, 705.6 kHz or 768 kHz sampling frequency is played back, digital audio output is not available.

This is a shutter-type optical terminal. Direct the cable connector correctly when inserting the cable into the terminal. If the cable connector is inserted forcibly in the wrong direction, the terminal may be deformed and the shutter may not be able to close even after disconnecting the cable.

10. Coaxial digital output terminal (COAX)

This terminal is connected to an amplifier that has a digital input terminal using a coaxial digital cable. When a Super Audio CD (HD layer selected) or a DSD file is played back, a digital audio output cannot be not provided.

In addition, when PCM data of 352.8 kHz, 384 kHz, 705.6 kHz or 768 kHz sampling frequency is played back, digital audio output is not available.

11. Main power switch (MAIN POWER)

Turns this unit to the standby state. When this switch is set to ON/STANDBY, the standby indicator on the front panel lights up to show that this unit turns to the standby state.

When this switch is set to OFF, the standby indicator on the front panel turns off to show that the main power is turned off.

12. Power cable terminal (AC IN)

Connect the accessory power cable here to supply power from the AC outlet on the wall.

Connections

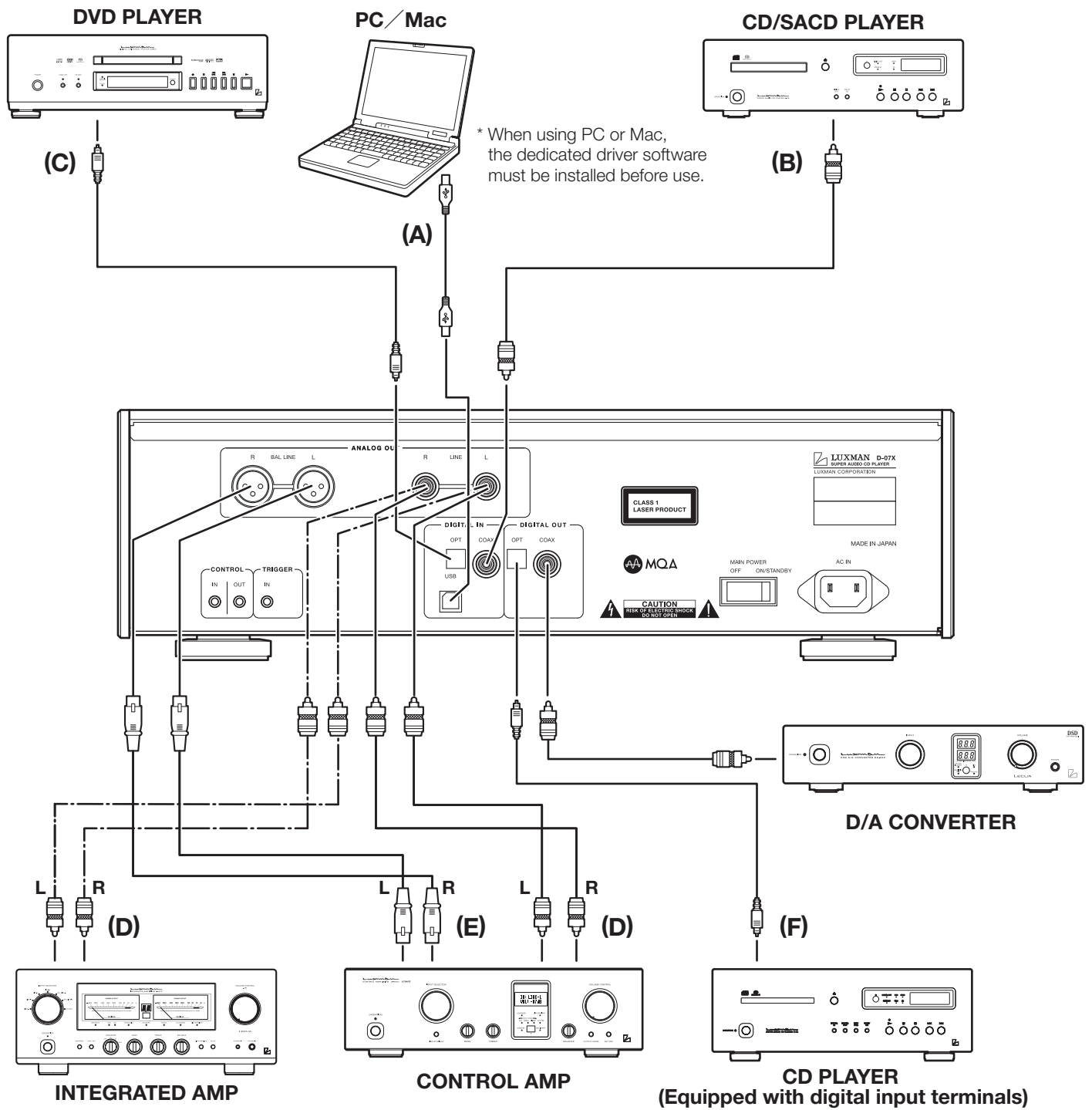

Before connecting

Before connecting other devices, connect the jack side of the accessory power cable to the AC inlet of this unit.

When connecting, turn off the power supply for this unit and the power supplies of all auxiliary devices to prevent unexpected accidents that may be caused by noise.

Connecting to the power supply

Connect the supplied accessory power cable here to power the unit from an AC wall outlet.

How to connect input devices

1. Digital connection from a PC/Mac (Refer to the connection diagram (A).)

Connect between the USB (A-type) terminal of the PC or Mac and the USB (B-type) terminal of this unit with a USB cable.

Before connecting this unit to a PC or Mac the dedicated driver software needs to be downloaded from LUXMAN website and installed.

Refer to "Driver Installation Manual" on the LUXMAN website for detailed information.

Caution:

Connection between a PC or Mac and this unit using a USB cable should not be performed before the installation of the dedicated driver software is completed. Failure to observe this may cause a malfunction.

2. Digital connection from a device such as a CD player (Refer to the connection diagrams (B) and (C).)

Connect between the (coaxial or optical) digital output terminal of a CD player, an SACD player, a DVD player or other such devices and the digital input terminal (COAX/OPT) of this unit with a coaxial digital cable and an optical digital cable.

This terminal is a shutter-type optical terminal. Direct the cable connector correctly when inserting the cable into the terminal. If the cable connector is inserted forcibly in the wrong direction, the terminal may be deformed and the shutter may not be able to close even after disconnecting the cable.

Upper side

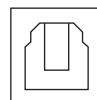

Lower side

The optical terminal is mounted as illustrated.

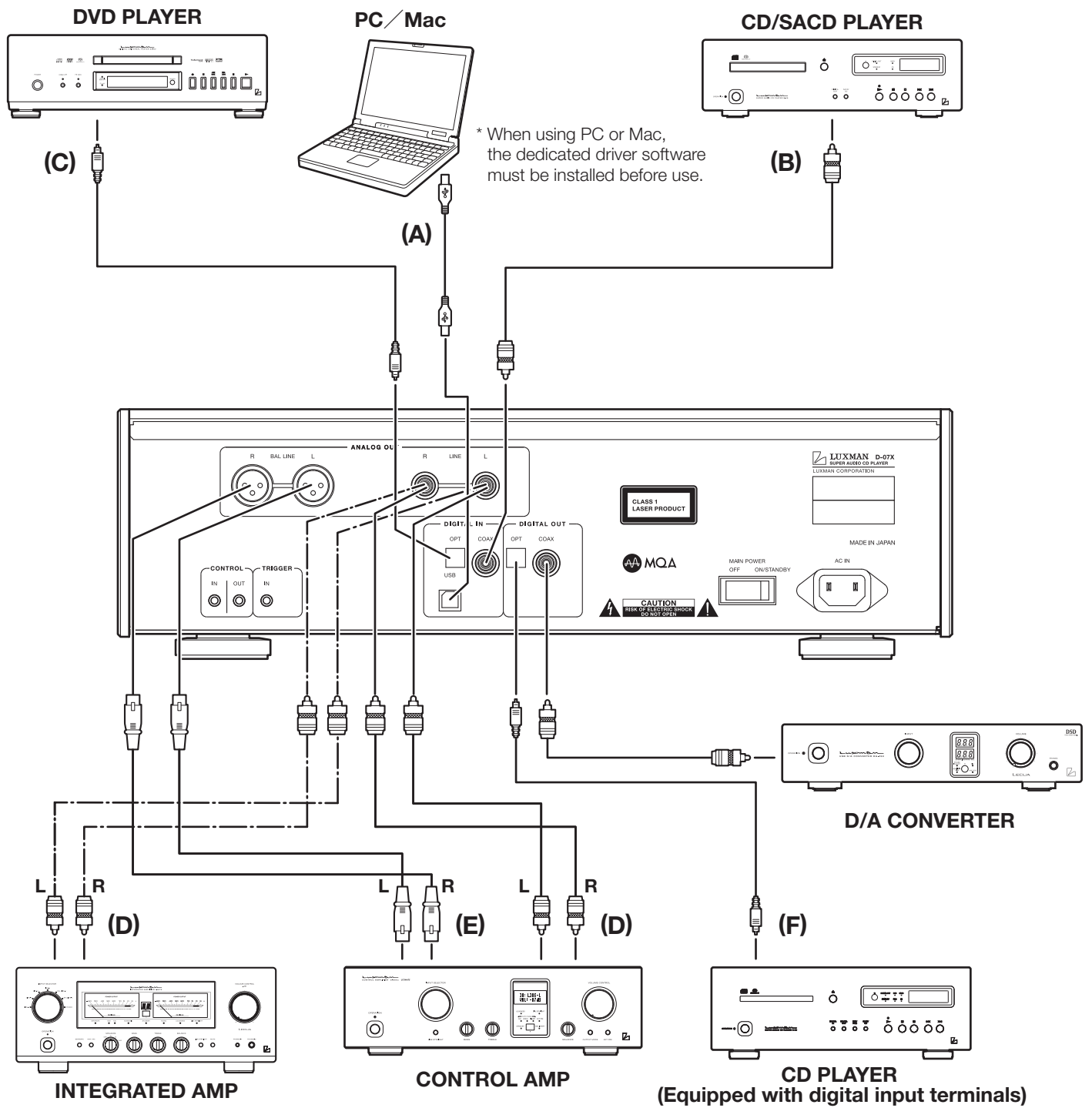

How to connect output devices

1. Unbalanced connection with a device such as an integrated amplifier (Refer to connection diagram (D).)

Connect between the analog unbalanced output terminals (LINE) of this unit and the unbalanced input terminals of a device such as an integrated amplifier with 2 (L/R) RCA-plug cables.

2. Balanced connection with a device such as a pre-amplifier (Refer to connection diagram (E).)

Connect between the balanced analog output terminals (BAL LINE) of this unit and the balanced input terminals of a device such as an integrated amplifier with two balanced XLR cables (L/R).

3. Digital output to a device such as another D/A converter (Refer to connection diagram (F).)

Connect between the digital output terminal (COAX/OPT) of this unit and a device such as a D/A converter or a unit equipped with digital input terminals with a coaxial digital cable or an optical digital cable.

How to connect between the trigger input terminal and other devices

Use a commercially available 3.5 mm monaural mini-plug cable to connect to a device with a trigger output terminal. This connection enables this unit to turn to operation/standby in conjunction with the connected device.

When connection is conducted from a product made by other than LUXMAN, make sure that the trigger output is 12 V. The trigger input of this unit should be 12 volts, the current consumption is 13 mA.

How to Play Back Discs

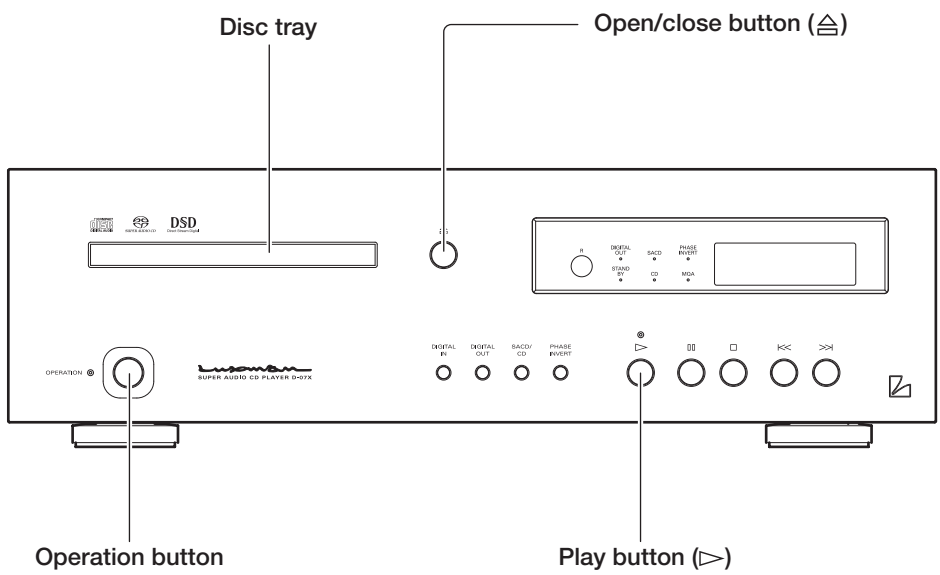
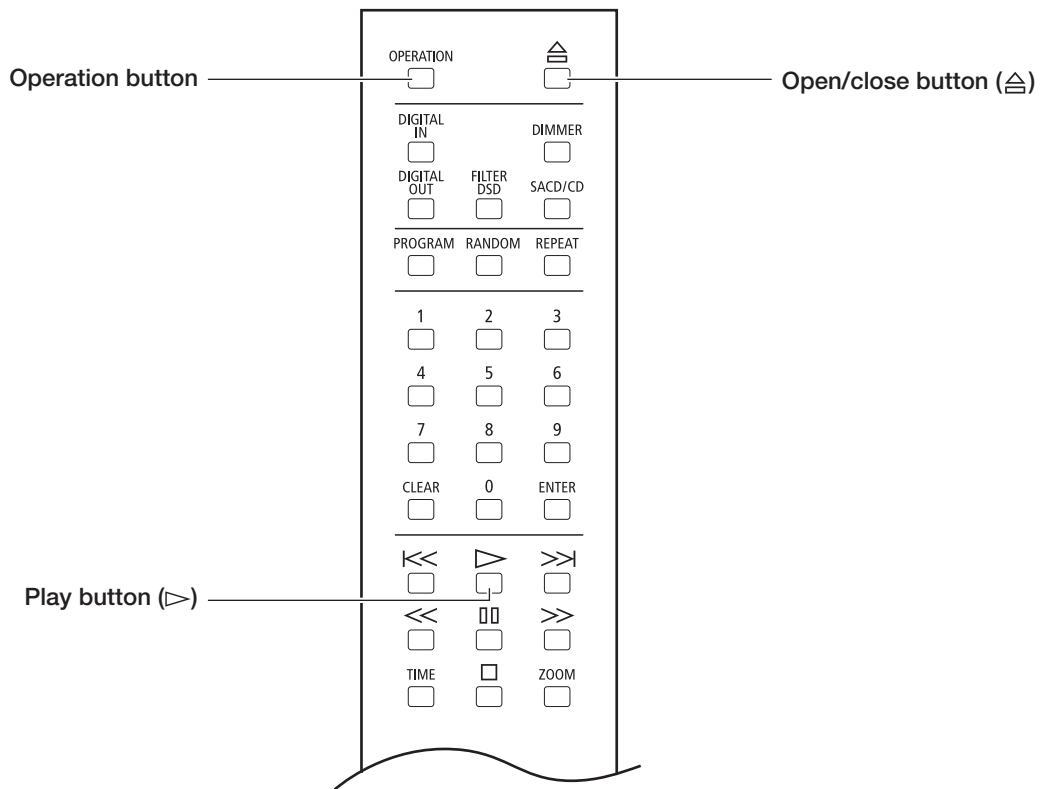

Disc Playback



1. Press the OPERATION button.

When “-OPERATION-” appears and then disappears, the unit becomes operable.

2. Press the open/close (⏏) button.

The disc tray opens.

3. Place the disc on the disc tray according to the guide on the tray.

4. Press the open/close (⏏) button.

The disc tray closes and the disc is loaded.

To start playback quickly, press the play (▶) button without pressing the open/close (⏏) button.

Or select a track by pressing a numeric key without pressing the open/close (⏏) button, and press the ENTER button or play (▶) button.

Operation buttons and numeric keys are not functional during the period from disc loading to displaying of disc type. Specifying the next operation, for example specifying the number of tracks beforehand, can shorten the time before playback start.

5. Press the play (▶) button.

Stop/pause the Playback

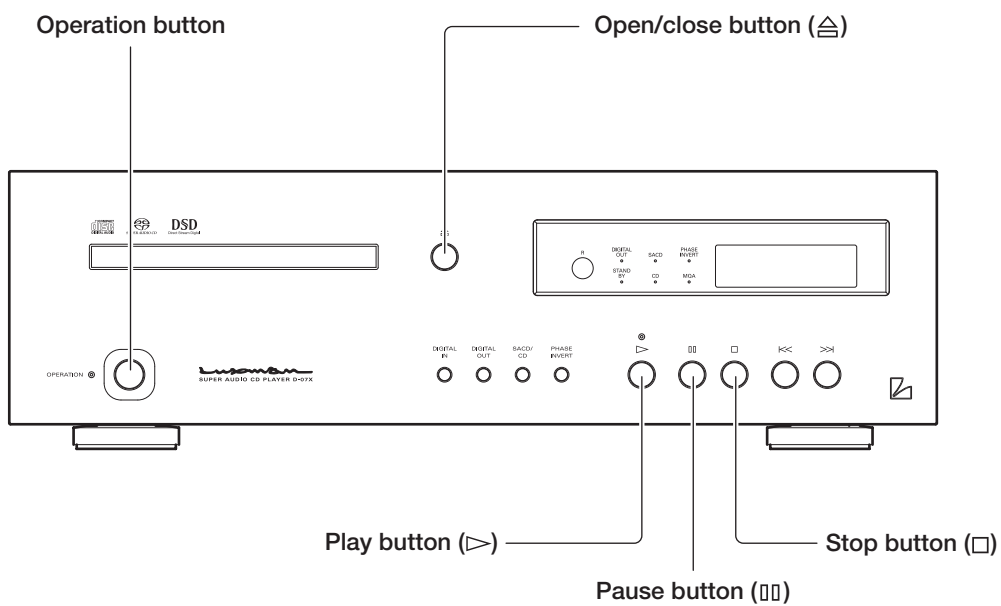
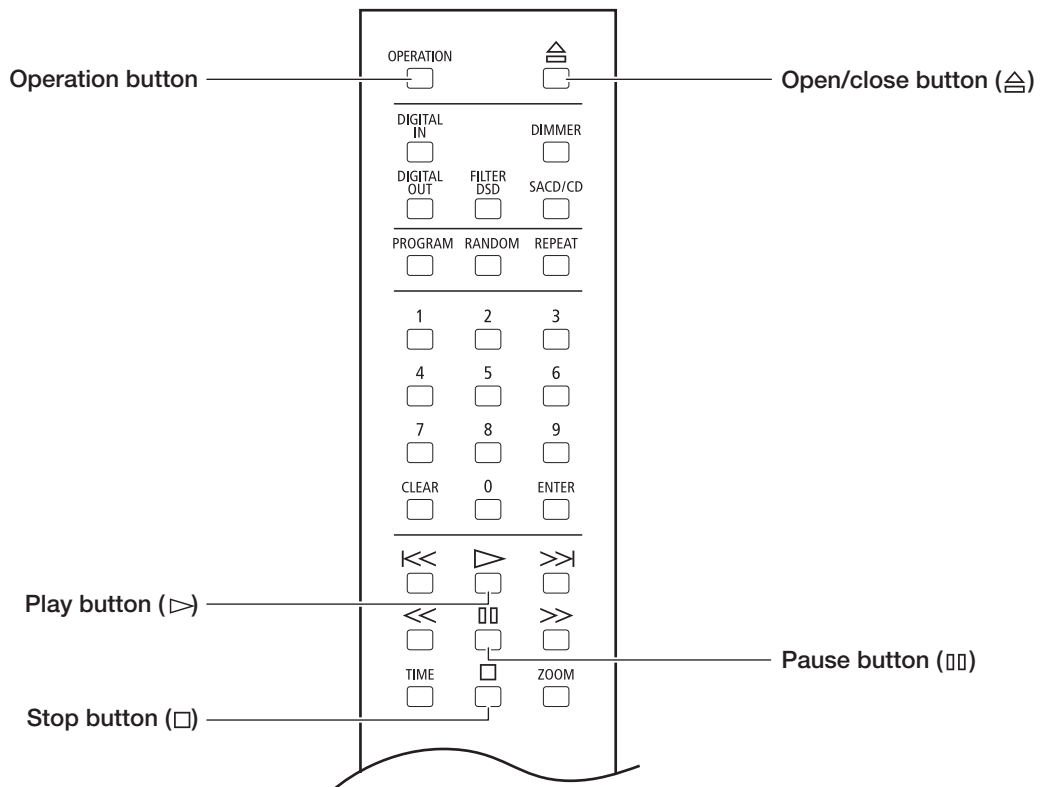

Pause/stop the playback of the disc



How to pause playback

Press the pause (⏸) button.

During pause, the play indicator blinks.

Resumes the regular playback.

During pause, press the play (▶) or pause (⏸) button.

Stop the playback.

During playback, press the stop (⏹) button.

Eject a disc.

Press the open/close (⏏) button.

The disc tray opens.

Turn off the unit. (Turn the unit to the standby state.)

Press the OPERATION button.

"-STANDBY-" appears on the display, and the STANDBY indicator lights up.

To turn off the power completely, the main power switch on the rear panel needs to be turned off.

Skip/Fast-forward/Rewind

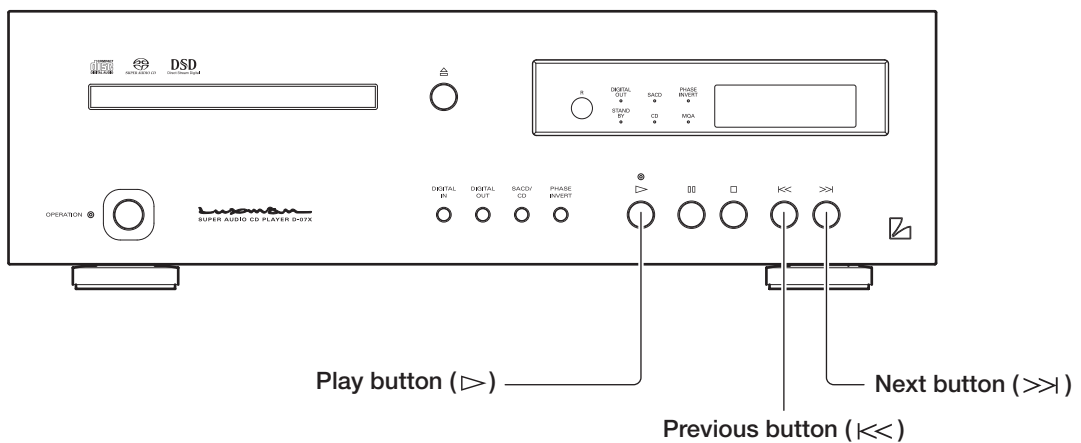
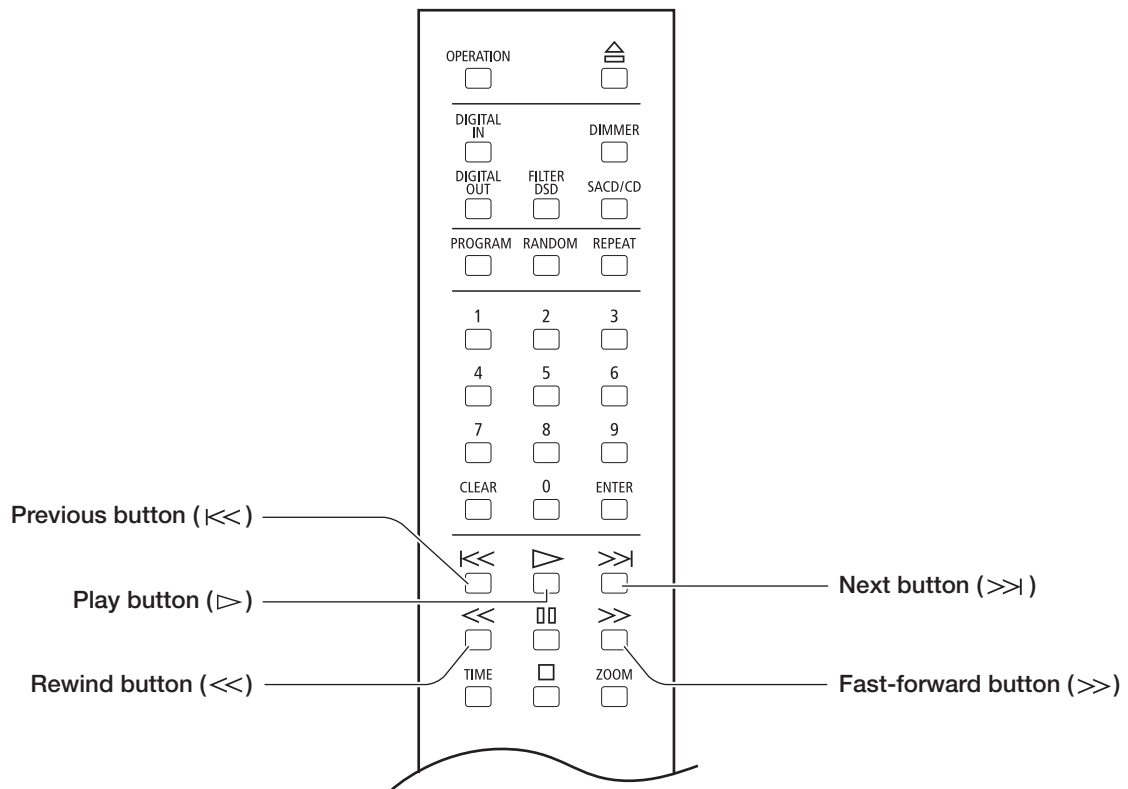

Skipping to a desired track (cue function)



Skip playback Skip to a desired track

To skip to a particular track to play back, press the next button (>>) repeatedly until the desired track is displayed.

Go back to a desired track

To go back to a particular track to play back, press the previous button (<<) repeatedly until the desired track is displayed.

When this button is pressed once, the playback returns to the beginning of current track. When this button is pressed twice, playback returns to the beginning of the previous track.

Disc fast-forward/rewind playback (Scan)



Fast-forward the playback.

1. During playback, press the fast-forward (>>) button.

Each time the button is pressed, the fast-forward speed can be changed in 4 steps.

">>1, >>2, >>3, >>4" appears on the display to indicate the fast-forward state and speed.

2. To resume regular playback, press the play (▷) button.

Rewind the playback.

1. During playback, press the rewind (<<) button.

Each time the button is pressed, the rewind speed can be changed in 4 steps.

"<<1, <<2, <<3, <<4" appears on the display to indicate the rewind state and speed.

2. To resume the regular playback, press the play (▷) button

When a set of tracks are composed of two or more SACDs, the first track may not be Track 1.

Direct search/repeat playback

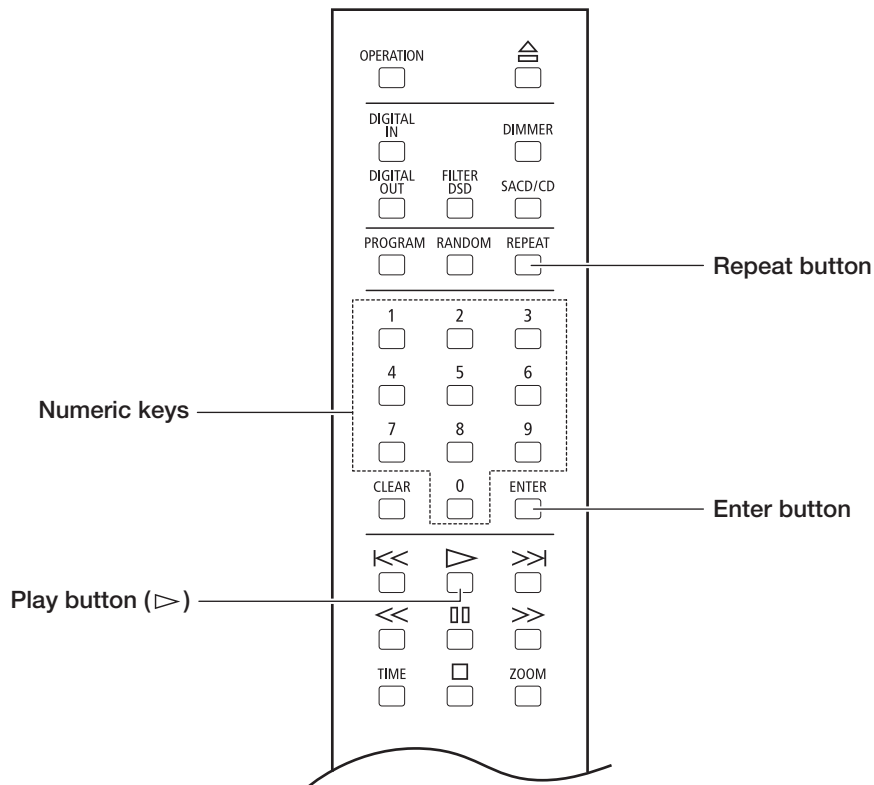

Specify the desired track for playback

Remote control

1. Enter a track number by pressing numeric keys.

For example, when selecting the 15th track, press the “1” key, and then “5”.

2. Press the enter or play button.

Playback is started automatically even without pressing the ENTER button after the elapse of approx. 4 seconds. The maximum number of tracks is 255 for a Super Audio CD, and it may take longer time to enter a 3-digit track number. For this reason, approx. 4 seconds are given to CDs before auto jump.

Repeat playback

Remote control

There are two types of repeat playback: track repeat (T-REP) and all repeat (A-REP).

Track repeat (T-REP)

1. During playback, press the REPEAT button once.

2. "T-REP" appears on the display to indicate the track repeat.

3. When this button is pressed twice again, the track repeat is canceled.

Repeat playback is also canceled when the disc is stopped.

All repeat (A-REP)

1. During playback, press the REPEAT button twice.

2. "A-REP" appears on the display to indicate all tracks repeat mode.

3. When this button is pressed once again, the track repeat is canceled.

Repeat playback is also canceled when the disc is stopped.

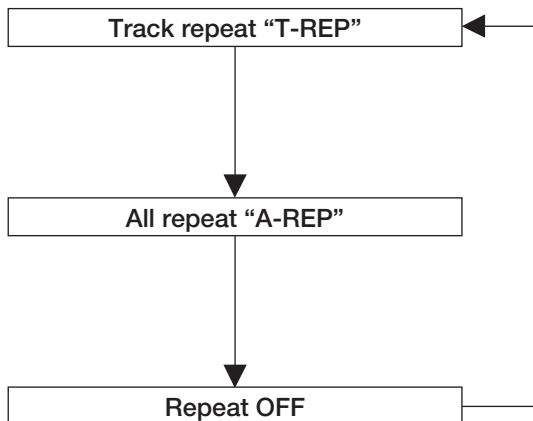

Program Playback

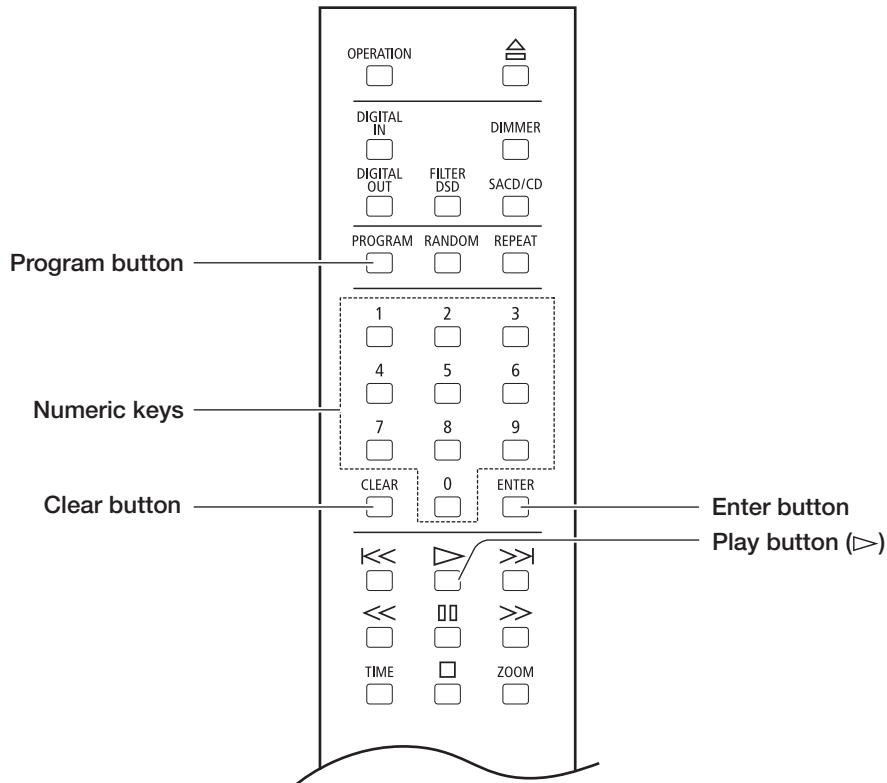

Playback of tracks in a programmed order (Program playback)

Remote control

It is possible to program up to 24 tracks in the desired order.

1. During stop, press the PROGRAM button.

The following indication appears on the display.

```

T-TIME
PG 00 00:00
    
```

2. Enter a desired track number by pressing the numeric keys of the remote control.

For example, when selecting the 5th track, press the "5" key.

```

PG 01 5
    
```

3. Press the ENTER button.

The order of the track is determined, and then track number and total time appear on the display.

```

T-TIME
PG 01 01:28
    
```

4. Enter the track number to program next.

For example, when selecting the 15th track, press the “1” key, and then “5”.



5. Press the ENTER button.

The order of the track is determined, and then track number and total time appear on the display.



Program your desired track order by repeating Step 2 and 3.

6. Press the play (▷) button.



- When pressing the PROGRAM button with the disc stopped, all programmed data is deleted.
- When pressing the CLEAR button with the disc stopped, tracks are deleted from the program in reverse order.
- It is impossible to program a pause.
- When pressing the REPEAT button during program playback, all programmed tracks will repeat.
- Track repeat is not available during program playback.
- When pressing the next (>>) button during program playback, the playback jumps to the next programmed track.
- To perform the program playback again, press the play (▷) button when the disc has stopped.

Procedure

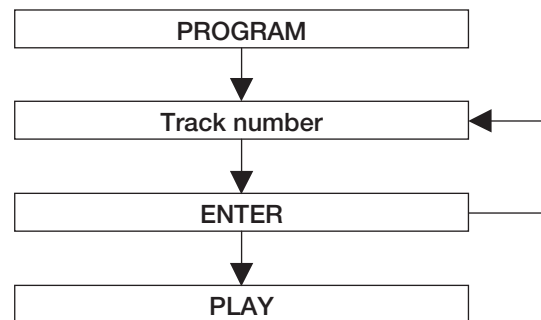

Random playback/disc information/zoom

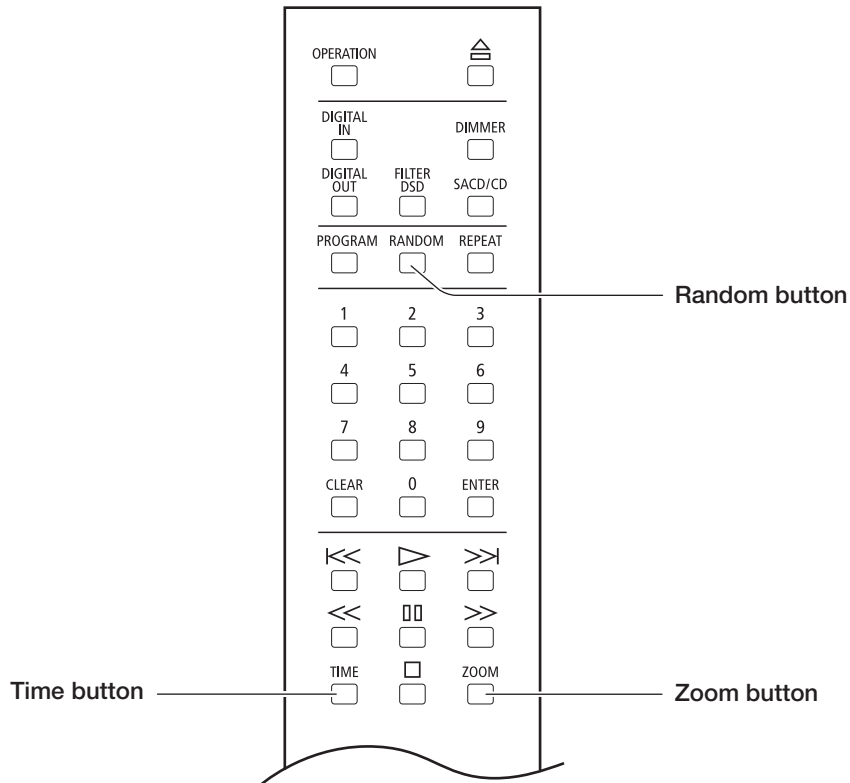

Playback of tracks in a random order (Random playback)

Remote control

Each track is selected from all disc tracks and is played back once.

1. Press the RANDOM button.

2. “RD” appears on the display to indicate random playback. Playback stops automatically after all the tracks on the disc have been played back.

Random playback stops when a disc is stopped or the RANDOM button is pressed once again. When pressing the next (>>|) button during random playback, the next track is randomly selected and played back. When pressing the previous (|<<<) button, the playback returns to the beginning of current track.

Disc information

Remote control

Altering the time display during playback.

Each time the TIME button is pressed during playback, the display changes as follows.

1. **The current track number and the elapsed time of the track (In the default setting)**
"TRK" will appear on the display.
2. **The current track number and the remaining time of the track (Remain)**
"TRK" and "REM" will appear on the display.
3. **The total remaining time of the disc (Total remain)**
"T-REM" will appear on the display window.

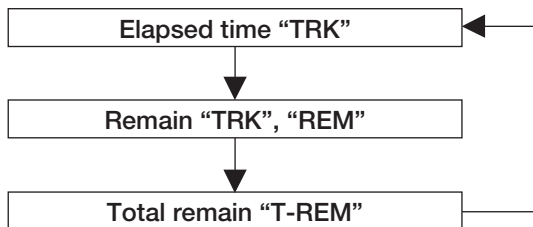

Zoomed display

Remote control

Enlargement of displayed characters

1. **Pressing the ZOOM button allows the track number and time to be displayed larger.**
2. **When pressing the ZOOM button once again, the display returns to the normal state.**

Normal display

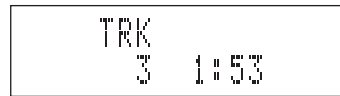

Zoomed display

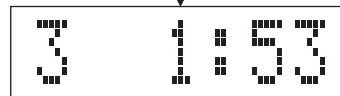

Detailed Settings

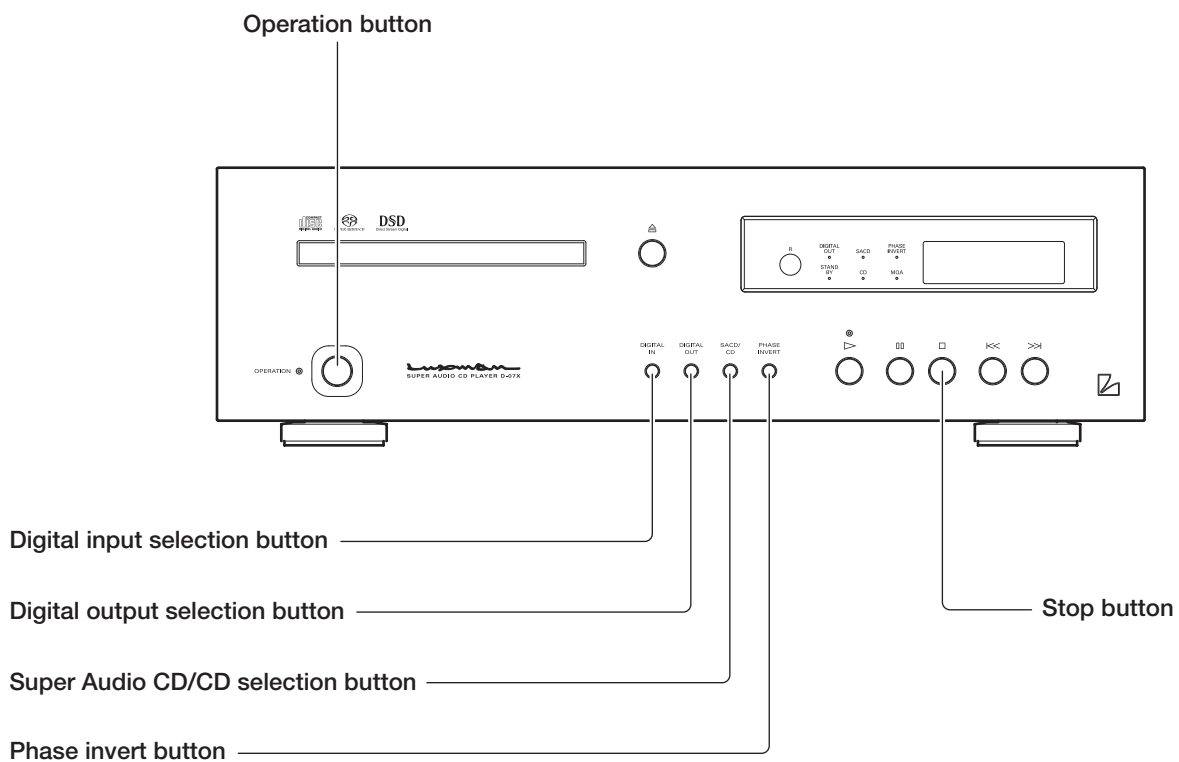
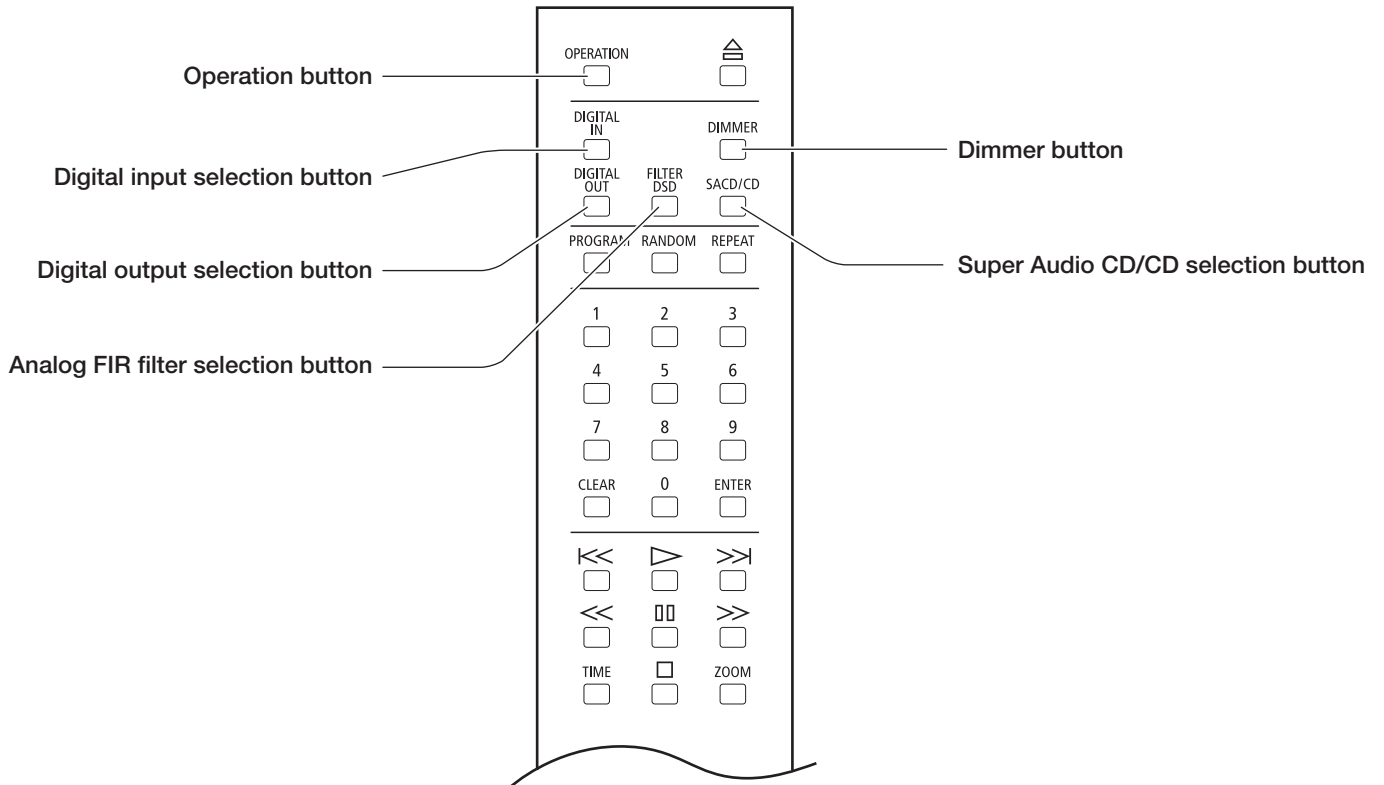

Dimmer button (DIMMER)



The brightness of the main unit display can be adjusted. The brightness can be adjusted in 4 steps from off, through two dim levels, to normal.

Each time the DIMMER button is pressed, the display changes as follows. Normal brightness → Dim → Very dim → No light → Normal brightness → ...

Selection of no light displays "DISPLAY OFF" for 2 second then the display turns off.

The brightness of LED indicators such as "SACD" and "DIGITAL OUT" cannot be changed.

Super Audio CD/CD selection button (SACD/CD)

 • 

When playing back a Hybrid Super Audio CD, this button should be pressed to select between the HD (or SACD) layer and the CD layer of the disc.

With the disc stopped, press the SACD/CD button.

Every time this button is pressed, the playback layer alternates between the HD (or SACD) layer and CD layer of the disc.

When the HD layer is selected, the Super Audio CD (SACD) indicator lights up on the main unit display.

When the CD layer is selected, the CD indicator lights up on the main unit display.

-
- This setting remains active even when another Hybrid Super Audio CD is loaded.
 - When a single-layer CD or dual-layer CD is loaded, the HD layer is automatically selected.
 - This unit does not support SACD multi-channel areas.
-

Detailed Settings

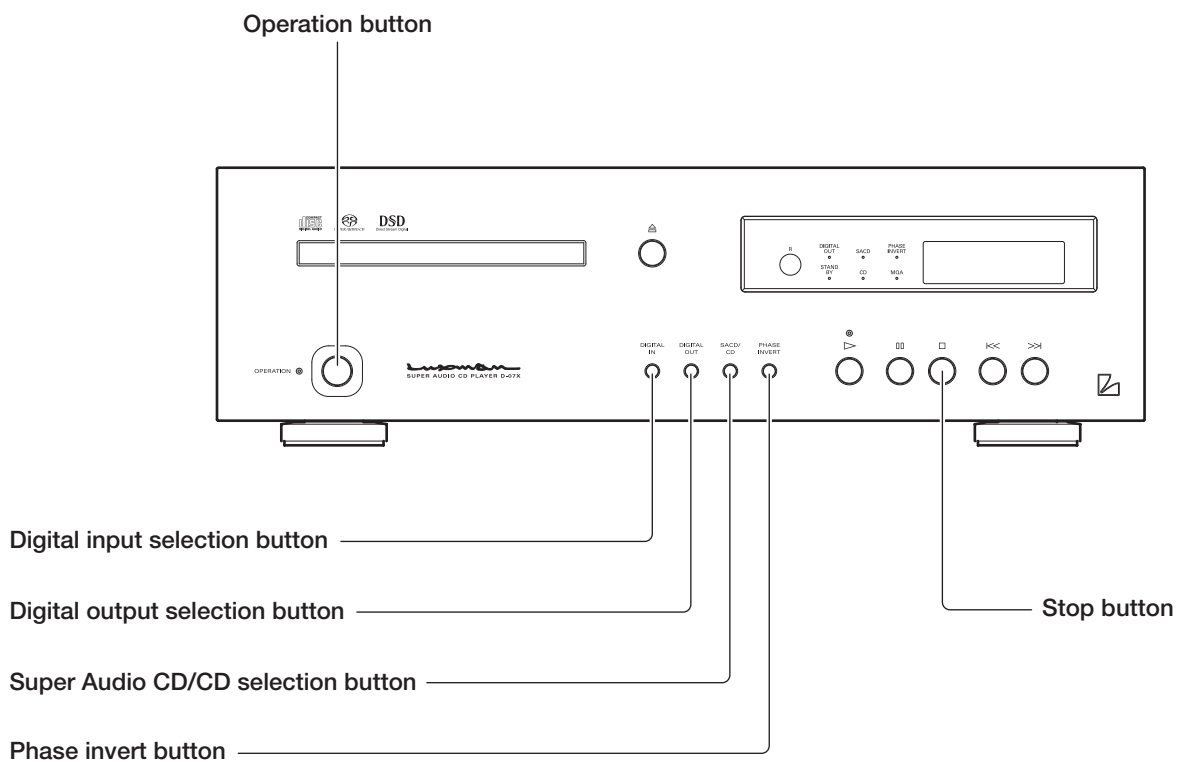
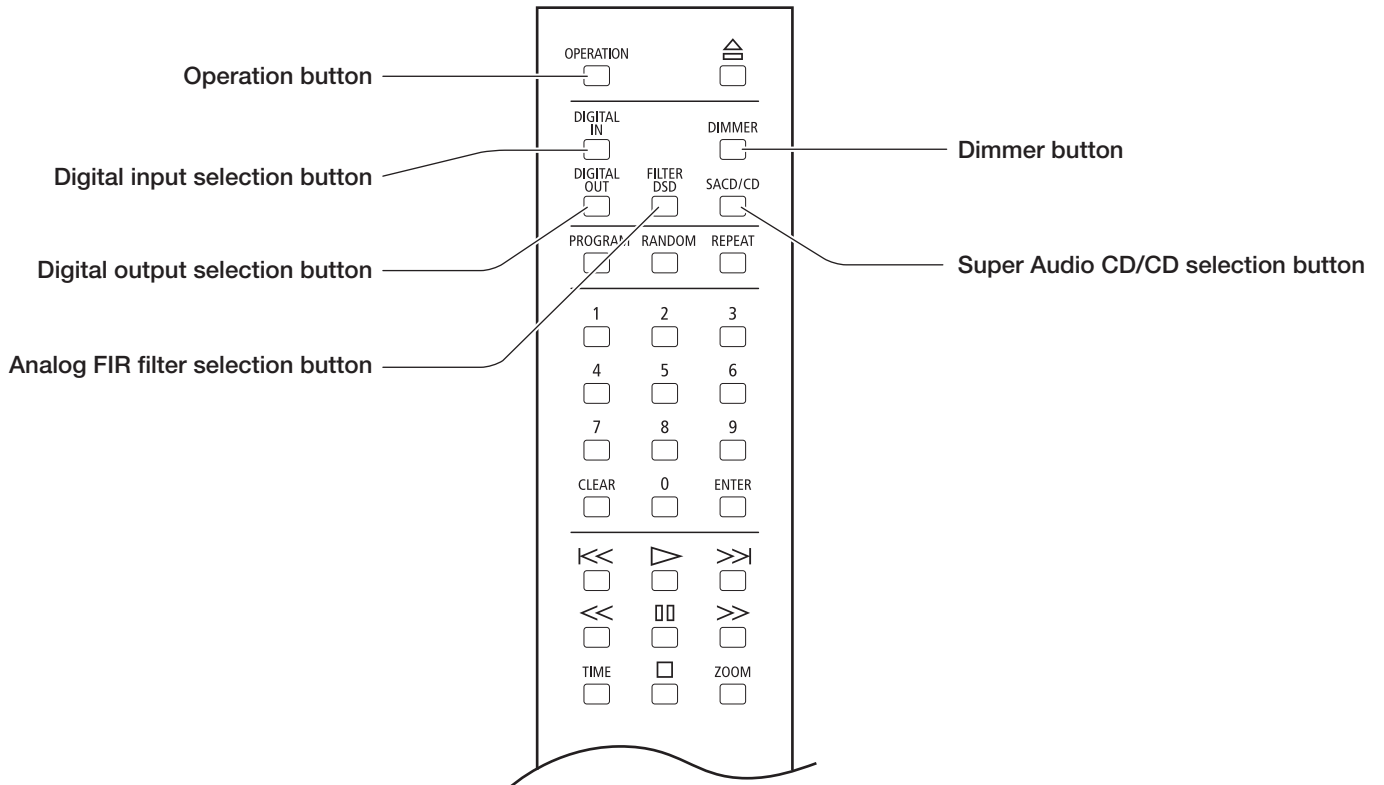

Digital input selection (DIGITAL IN) button



Press this button when using the unit as a D/A converter.

1. Each time the DIGITAL IN button is pressed, the display changes as follows. COAXIAL → OPTICAL → USB → INTERNAL (Internal player)

The coaxial and optical inputs support the following signals.

Sampling frequency: 44.1 kHz, 48 kHz, 88.2 kHz,
96 kHz, 176.4 kHz, 192 kHz

Quantization bit rate: 16-bit, 20-bit, 24-bit

The USB input supports the following signals.

- PCM signal

Sampling frequency: 44.1 kHz, 48 kHz, 88.2 kHz,
96 kHz, 176.4 kHz, 192 kHz,
352.8 kHz, 384 kHz,
705.6 kHz, 768 kHz

Quantization bit rate: 16-bit, 24-bit, 32-bit

- DSD signal

Sampling frequency: 2.8 MHz, 5.6 MHz,
11.2 MHz, 22.4 MHz

Quantization bit rate: 1-bit

When using PC or Mac, the dedicated driver software needs to be downloaded from the LUXMAN website and installed. Refer to "Driver Installation Manual" on the LUXMAN website for detailed information.

Caution:

Connection between a PC or Mac and this unit using a USB cable should not be performed before the installation of the dedicated driver software is completed. Failure to observe this may cause a malfunction.

2. The selected input type and sampling status are displayed on the main unit display window.

The sampling frequency and bit count of the current digital input signal are displayed, the input source connected to the digital input terminals (COAX/OPT/USB) are selected with the digital input selection button. When one of COAXIAL/OPTICAL/USB is selected using the digital input selection button and the digital signal from each digital device and this unit are synchronized, the sampling frequency and bit count of the digital signal are displayed.

When a digital signal input is not provided or the signal is not synchronized even if the signal input is provided, "UNLOCK" is displayed.

When USB is selected, only the sampling frequency is displayed. The bit count is not displayed.

-
- **The bit count (word length) indicates the contents of the word length data included in the channel status which is specified in IEC60958-3 (digital audio interface - Part 3: consumer applications).**

Some output devices may provide channel status data (word length data) whose content is different from the actual word length. In such a case, the contents of the channel status data are indicated on the display instead of the actual bit count.

Alternatively, some devices or sources may provide data which states "word length is not specified". In such a case, the bit count is not displayed.

- **There may be a case where the display indicates "LOCK" for a short time, and then "UNLOCK". (The reverse case is also possible.) That is because the former state (LOCK/UNLOCK) is indicated for approximately 0.5 seconds after an input signal is changed until the decoding circuit becomes stable.**
-

Detailed Settings

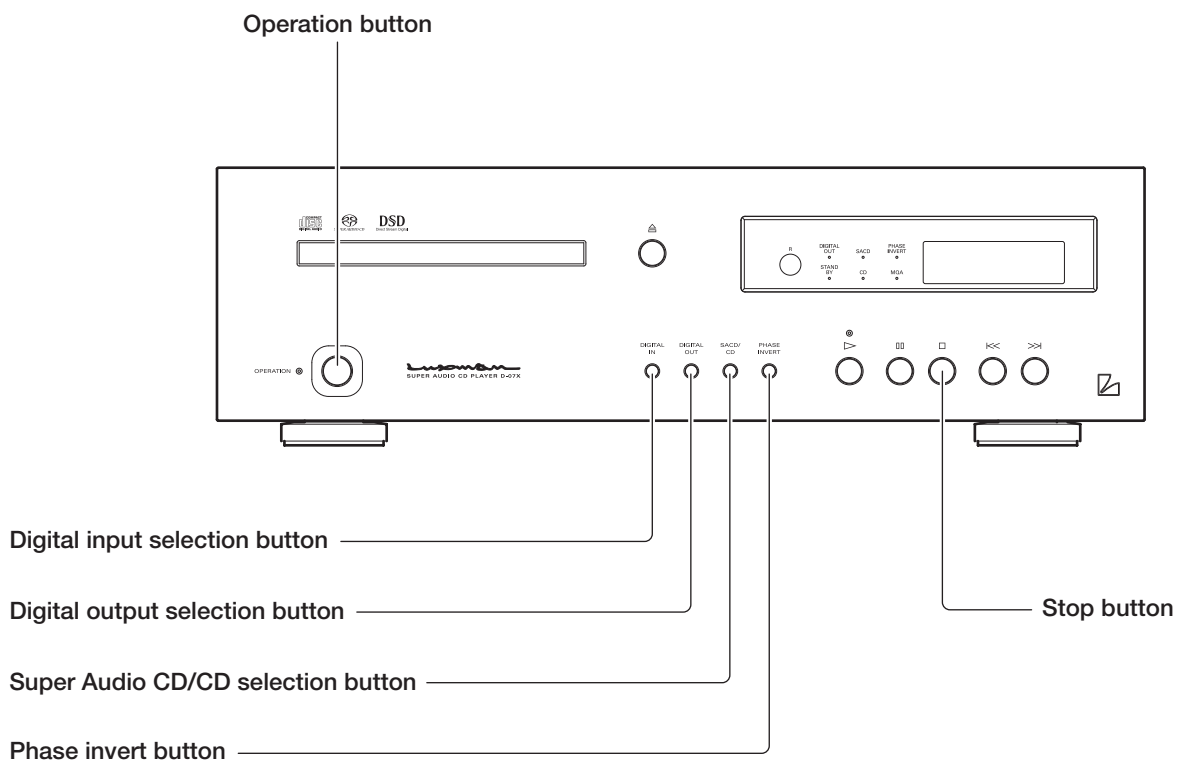
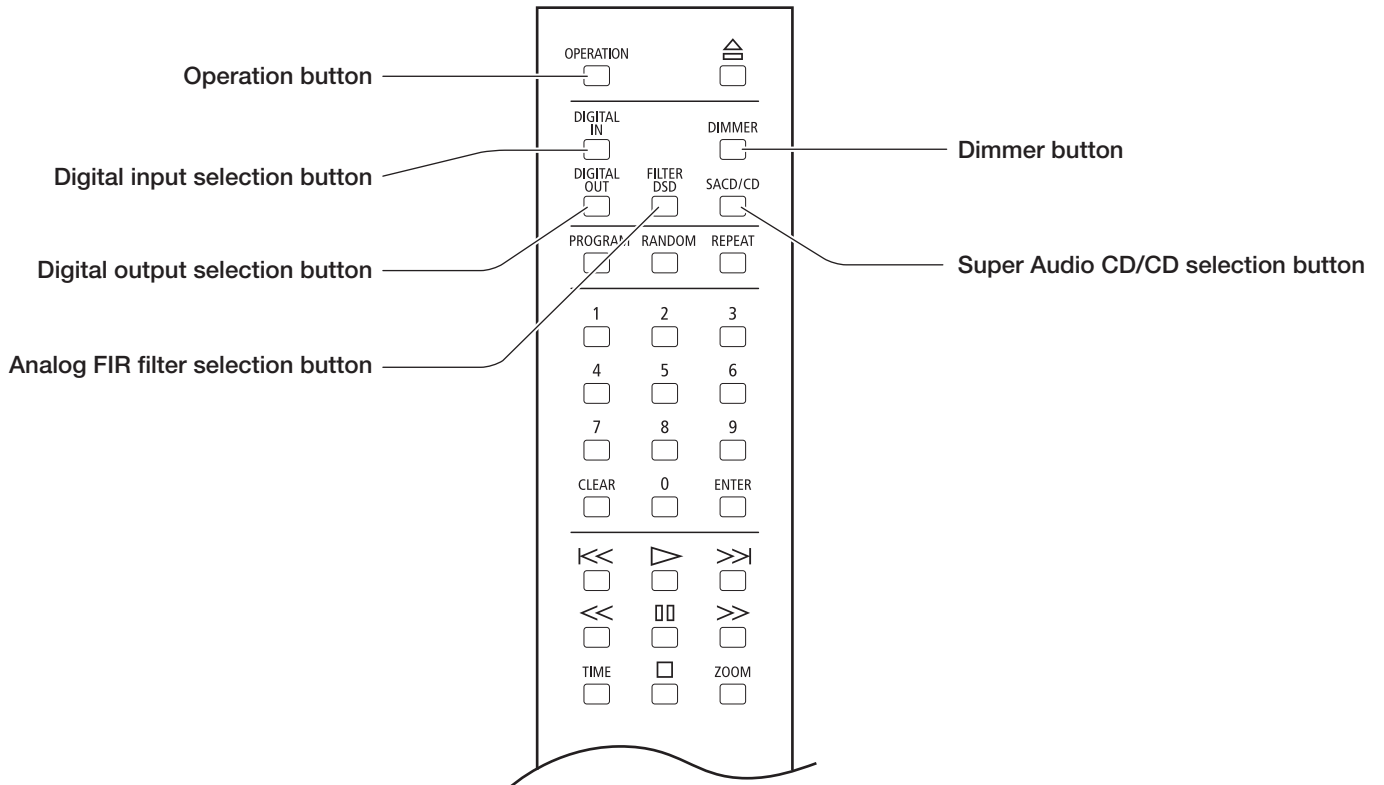

Digital output selection (DIGITAL OUT) button



Use this button to engage the unit's digital audio output. Each time the button is pressed, the output will be turned on or off.

When the HD layer of a Super Audio CD or a DSD file is played back, a digital audio output is not available. In this case, the DIGITAL OUT indicator turns off.

It is possible to turn on or off the digital audio output when playing back the CD layer of Hybrid Super Audio CD.

When PCM data of 352.8 kHz, 384 kHz, 705.6 kHz or 768 kHz sampling frequency is played back, digital audio output is not available.

Phase invert button (PHASE INVERT)



Use this button to invert the phase of the analog outputs on the rear panel.

Both the balanced output and unbalanced output are inverted.

This setting is stored on the flash memory even when the power is turned off.

Every time this button is pressed, the balanced phase changes as follows: NORMAL → INVERT → NORMAL → INVERT → ...

[Phase Normal]

1. GROUND
2. COLD (-)
3. HOT (+)

[Phase Inverted]

1. GROUND
2. HOT (+)
3. COLD (-)

How to restore all the settings to the factory defaults

All settings can be restored to the factory defaults by the following method

1. Turn off the unit (standby mode).
2. Press the OPERATION button on the main unit while holding down the stop (□) button on the main unit. All the settings will be restored to the factory defaults.

Item	Default
Digital input selection	INTERNAL (Internal player)
Digital output selection	ON
Super Audio CD/CD selection	Super Audio CD (SACD)
Phase invert changeover	Normal
Dimmer adjustment	Normal
Analog FIR filter DSD	D-1
Zoomed display	Normal

Last memory function (Memorization of each setting)

The following table shows the settings which are saved to the flash memory.

If the power is turned off immediately after changing any settings, the settings may not be successfully stored in the units memory.

Item	Selection
Digital input selection	INTERNAL (Internal player), COAXIAL, OPTICAL, USB
Digital output selection	ON, OFF
Super Audio CD/CD selection	Super Audio CD (SACD), CD
Phase invert button	Normal/invert
Dimmer adjustment	Normal, Dim, Very dim, No light
Analog FIR filter DSD	D-1, D-2
Zoomed display	Zoomed, Normal

Block Diagram

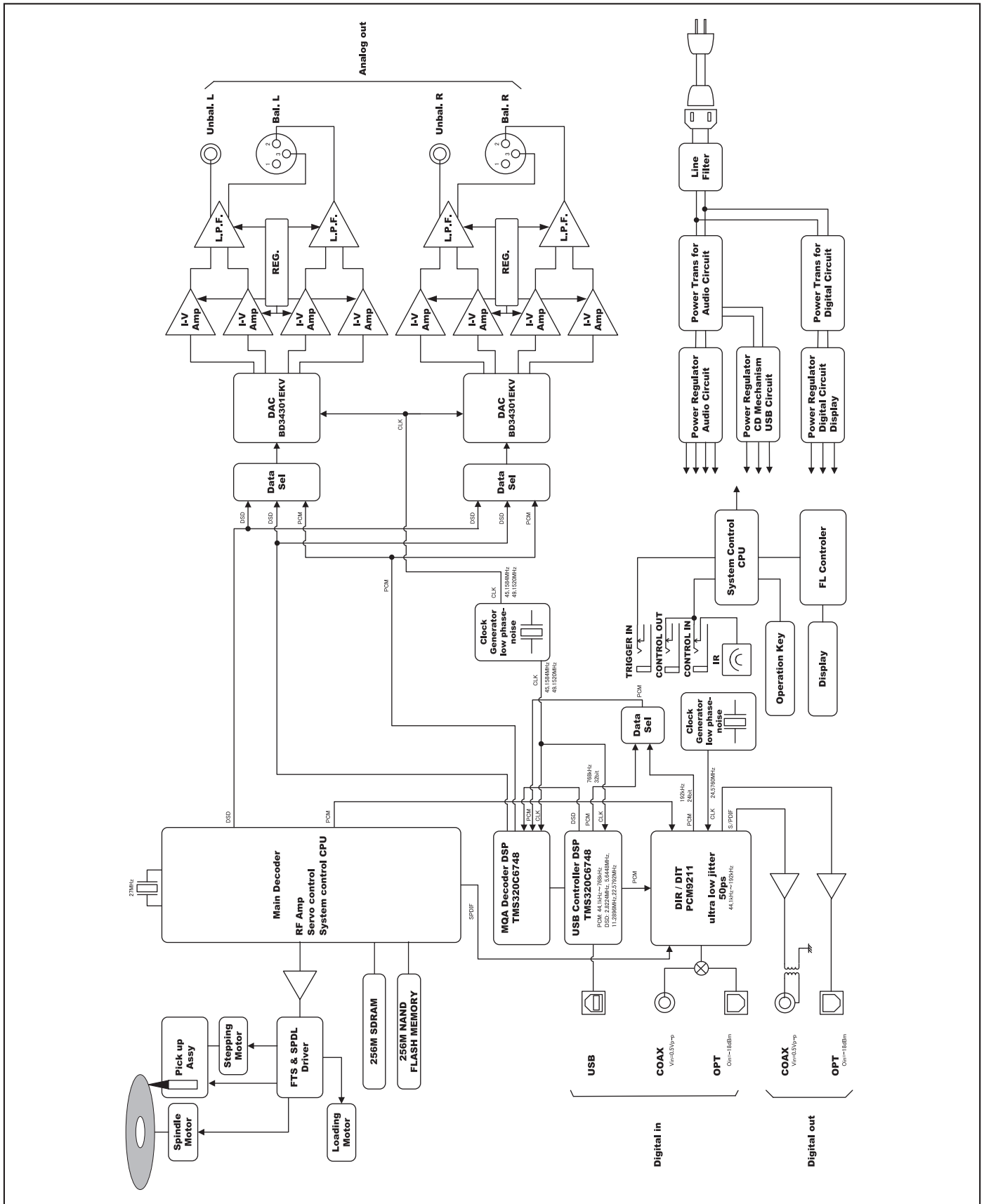

Specifications

luxman
SUPER AUDIO CD PLAYER D-07X

Format	2-channel SACD, CD			
Power supply	230 V ~ (50 Hz)			
Power consumption	37 W 1 W (at standby)			
Weight	17 kg (main unit)			
Max. external dimensions	440 (W) x 132 (H) x 410 (D) mm (front side knob with 2 mm and rear side terminal with 8 mm included in depth)			
Ambient operating temperature / Ambient operating humidity	+5 °C to +35 °C / 5 % to 85 % (non condensing)			
Audio output characteristics	Output voltage / output impedance	UNBALANCE terminal (RCA terminal)	2.4 Vrms/300 Ω	
		BALANCE terminal (XLR terminal)	2.4 Vrms/600 Ω	
		For SACD/DSD	2.3 Vrms	
	Frequency response:	CD	5 Hz to 20 kHz (+0, -0.5 dB)	
		SACD	5 Hz to 38 kHz (+0, -3 dB)	
		USB	5 Hz to 47 kHz (+0, -3 dB)	
	Total harmonic distortion:	CD	0.0016 %	
		SACD	0.0007 %	
		COAX/OPT	0.001 %	
		USB	0.001 %	
S/N ratio:	CD	122 dB		
	SACD	125 dB		
	COAX/OPT	122 dB		
	USB	122 dB		
	Dynamic range:	CD	100 dB	
		SACD	107 dB	
		COAX/OPT	122 dB	
		USB	121 dB	
Channel separation:	CD	119 dB		
	SACD	122 dB		
	COAX/OPT	119 dB		
	USB	119 dB		
Digital input	Coaxial digital input:	0.2 to 2.5 Vp-p		
	Optical digital input:	-14.5 to -21 dBm		
	USB input: (Applicable OS)	Microsoft Windows 10 or later, macOS10.15 or later		
	Sampling frequency:	OPT/COAX:	44.1 kHz, 48 kHz, 88.2 kHz 96 kHz, 176.4 kHz, 192 kHz (16-bit, 20-bit, 24-bit)	
		USB input:	44.1 kHz, 48 kHz, 88.2 kHz, 96 kHz 176.4 kHz, 192 kHz, 352.8 kHz, 384 kHz 705.6 kHz, 768 kHz (16-bit, 24-bit, 32-bit) 2.8 MHz, 5.6 MHz, 11.2 MHz, 22.4 MHz (1-bit)	
Digital output	Coaxial digital output:	RCA terminal 0.5 Vp-p/75 Ω		
	Optical digital output:	Optical digital terminal -15 to -21 dBm		

* Specifications and appearance are subject to change without notice.

Before Asking for Repair Service

While in use, this unit may display phenomena which may be confused as malfunctions. Before contacting your country's official LUXMAN distributor for repair services, please read the operating instructions for any connected input and output devices and check the troubleshooting table below. If the cause of the malfunction cannot be identified, please contact your dealer. After LUXMAN's representatives have accepted your request for repair services, inspection fees and transportation expenses may be claimed, even though the unit may be found to be operating normally.

Besides, such personal computer as a PC/Mac connected to the unit and the software that operates on the PC/Mac (operations and settings included) are not supported.

Problem	Cause/Solution	Ref. page
No power is supplied.	<ul style="list-style-type: none"> • Connect the power cable to the AC inlet and the AC outlet firmly. 	20
The disc tray comes out even after the tray is closed.	<ul style="list-style-type: none"> • Place the disc on the disc tray correctly. • Clean the disc to remove dirt. 	24 2
Playback cannot be performed.	<ul style="list-style-type: none"> • Clean the disc to remove dirt. 	2
	<ul style="list-style-type: none"> • Place the disc on the disc tray correctly. 	24
	<ul style="list-style-type: none"> • Remove condensation from the interior of this unit. 	1
	<ul style="list-style-type: none"> • Place the disc on the tray with the label facing upwards. (label face upward) 	
No sound is generated. / Sound volume is too low. (Digital input)	<ul style="list-style-type: none"> • Connect digital cables correctly. 	19 - 20
	<ul style="list-style-type: none"> • If USB is selected as an input source, select this unit (D-07X) as the output destination by configuring the sound setting of your PC/Mac. 	Refer to the instruction manual of the PC/Mac or the software in use.
	<ul style="list-style-type: none"> • If the unit (D-07X) cannot be selected even when trying the solution above, disconnect, then reconnect the USB cable. 	
	<ul style="list-style-type: none"> • If USB is selected as an input source, adjust the sound volume by configuring the sound setting of your PC/Mac. 	
	<ul style="list-style-type: none"> • If USB is selected as an input source, adjust the sound volume on your PC/Mac player software. 	
	<ul style="list-style-type: none"> • Ensure that this unit supports the sampling frequency and the quantization bit rate of the desired digital input signal. 	18
	<ul style="list-style-type: none"> • Check to see whether digital input "UNLOCK" is displayed or not. (When a digital signal from a digital device is not synchronized with this unit, the source may not be played back.) 	
The remote control cannot be operated.	<ul style="list-style-type: none"> • Operate the remote control within the specified operating range. 	10
	<ul style="list-style-type: none"> • Replace the remote control batteries with new ones. 	9
	<ul style="list-style-type: none"> • The remote control infrared receiver is exposed to direct sunlight or strong light sources (such as inverter fluorescent lights). Change the installation place or angle to avoid the exposure to strong light sources. 	10
An electronic device such as a television malfunctions.	<ul style="list-style-type: none"> • Some devices equipped with a wireless remote control receiver may malfunction when the remote control of this unit is operated. Keep this unit away from such devices. 	10

Problem	Cause/Solution	Ref. page
No sound is generated from the speakers, or sound is distorted.	• Confirm that all audio cable connections are correct.	19 - 22
	• If a digital output device is connected to this unit, set [Digital output] to [On].	11
	• Clean the disc to remove dirt.	2
	• When the output level of an amplifier, etc. is minimum, adjust the volume.	
	• Confirm that the cable connectors are connected and firmly inserted into the terminals of all unit.	
Digital audio signals cannot be output digitally.	• Clean the cable connectors and terminals by using a plain dry cloth or a cloth dipped in a small amount of dehydrated alcohol.	
	• Set [Digital output] to [On].	11
The output levels of SACD and CD are quite different.	• When the HD layer of a Super Audio CD, a DSD file, or a PCM file with sampling frequency of 352.8 kHz, 384 kHz, 705.6 kHz or 768 kHz is played back, a digital audio output is not available.	18
	• This is due to the difference in recording format.	

This unit may not work normally when the unit is subject to external influence such as static electricity. In such a case, normal operation may resume by turning off the power once and turning on the power again after several tens of seconds or returning the unit to the factory setting. If the problem is not solved, please contact your dealer or our service center.

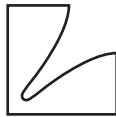

LUXMAN CORPORATION, JAPAN

1-3-1 Shinyokohama, Kouhoku-ku, Yokohama-shi, Kanagawa 222-0033, Japan

AG00238G10A
Printed in Japan