

# *Owner's Manual*

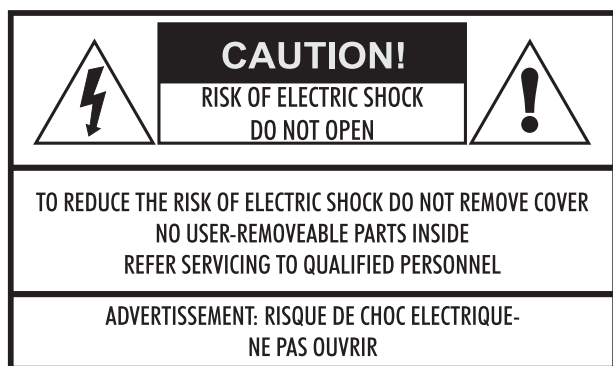

# Safety Caution



This lightning flash with arrowhead symbol within an equilateral triangle is intended to alert the user to the presence of non-insulated "dangerous voltage" within the product's enclosure that may be of sufficient magnitude to constitute a risk of electric shock.

**WARNING:** To reduce the risk of electric shock, do not remove cover (back) as there are no user-serviceable parts inside. Refer servicing to qualified personnel.

The exclamation point within an equilateral triangle is intended to alert the user to the presence of important operating and maintenance instructions in the literature accompanying the appliance.

Read these instructions.

Keep these instructions.

Heed all warnings.

Follow all instructions.

Do not block any ventilation openings. Install in accordance with the manufacturer's instructions.

Do not install near any heat sources such as radiators, heat registers, stoves, or other apparatus (including amplifiers) than produce heat.

Do not defeat the safety purpose of the polarised or grounding plug. A polarised plug has two blades with one wider than the other. A grounding plug has two blades and a third grounding prong.

The wide blade or the third prong is provided for your safety. If the provided plug does not fit into you outlet, consult an electrician for replacement of the obsolete outlet.

Protect the power cord from being walked on or pinched particularly at plugs, convenience receptacles, and the point where they exit from the apparatus.

Only use attachments/accessories specified by the manufacturer.



Use only with the cart, stand, tripod, bracket, or table specified by the manufacturer, or sold with the apparatus.

When a cart or rack is used, use caution when moving the cart/apparatus combination to avoid injury from tip-over.

Unplug the apparatus during lightning storms or when unused for long periods of time.

Refer all servicing to qualified personnel. Servicing is required when the apparatus has been damaged in any way, such as power supply cord or plug is damaged, liquid has been exposed to rain or moisture, does not operate normally, or has been dropped.

**CAUTION:** These servicing instructions are for use by qualified service personnel only. To reduce the risk of electric shock, do not perform any servicing other than that contained in the operating instructions unless you are qualified to do so.

**WARNING:** To reduce the risk of fire or electric shock, do not expose this apparatus to rain or moisture. The apparatus shall not be exposed to dripping or splashing and that objects filled with liquids, such as vases, shall not be placed on apparatus.

No naked flame sources, such as lighted candles, should be placed on the apparatus.

**WARNING:** The battery (battery or batteries or battery pack) shall not be exposed to excessive heat such as sunshine, fire or the like.

**WARNING:** The mains plug/appliance coupler is used as disconnect device shall remain readily operable.



This label tells you that the unit contains a laser component. Opening the unit will expose the user to radiation from the laser beam.



This equipment is a Class II or double insulated electrical appliance. It has been designed in such a way that it does not require a safety connection to electrical earth.



Correct disposal of this products. This marking indicates that this product should not be disposed with other household wastes throughout the EU. To prevent possible harm to the environment or human health from uncontrolled waste disposal, recycle it responsibly to promote the sustainable reuse of material resources. To return your used device, please use the return and collection systems or contact the retailer where the product was purchased. They can take this product for environmentally safe recycling.



# Contents



LUXMAN CORPORATION, JAPAN

Thank you for using LUXMAN Control Amplifier C-800f.

Please read this manual carefully before using the product to ensure that you use it appropriately, maximize the functions of the product and optimize the playback performance of the music.

After reading this manual, store it together with the warranty and safety instructions at an appropriate place.

Precautions.....	1
Names and Functions.....	2
How to Use Remote Control.....	18
Connections.....	19
C-800f Block Diagram .....	23
Specifications .....	26
Troubleshooting .....	27





# Precautions

---

## Installation place

This unit shall be installed in a wellventilated and effectively heatreleased place.

Especially, installation of this unit where direct sunlight is present, where the temperature rises excessively high such as close to a heater, or where it is humid or dusty may cause a malfunction even if heat is efficiently released. Therefore, do not install this unit in such places.

## Precautions in connecting with other components

When connecting this unit to input devices such as a CD/DVD player, a tuner, and a recorder, be sure to turn off the power of this unit and all other connected devices. Failure to observe this may generate a strong noise resulting in speaker damage or cause a malfunction. The pin-plug to be inserted in each input terminal of this unit shall be pushed in firmly. If the grounding terminal is inadequately connected, noises including hum may be generated, resulting in an adverse S/N ratio.

## The sound is not generated shortly after the power supply is turned on.

This amplifier is equipped with a time muting circuit in order to separate the output circuit. Therefore, no sound is generated shortly after the power supply is turned on. If the volume control is moved to a high sound level before the time muting circuit is canceled, a large sound is suddenly generated. Please be advised that the volume control shall be set to a low level at first and adjusted after sound comes out of the speakers.

## Repair and adjustment

When repairs or adjustments are needed, please ask the dealer where you bought the unit.

## Cleaning

For cleaning, use a piece of soft cloth to wipe the unit such as cleaning cloth available on the market. If the unit has become remarkably dirty, remove the dirt with soft cloth absorbing a small amount of neutral detergent, and then wipe the unit with dry cloth. Do not use a solvent like benzine or thinner because such a substance can damage the exterior.



# Names and Functions

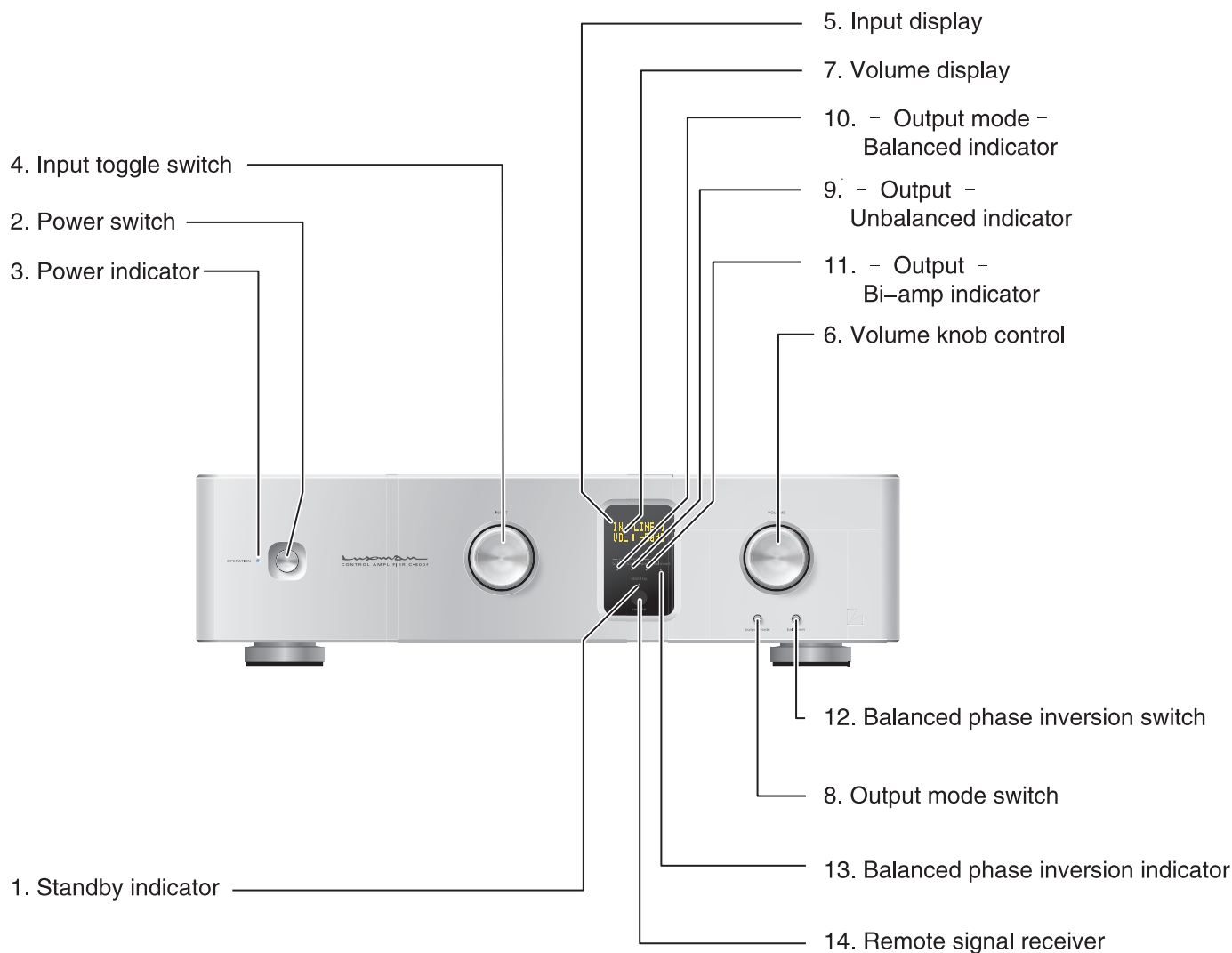

## 1. Standby indicator/stand by

This indicator lights up yellow when the power switch on the back panel is turned on, indicating that the product is in the standby status.

It goes out when the power switch is turned off, indicating that the product is switched off.

## 2. Power switch/OPERATION

When you press this switch in the standby mode, the standby indicator goes out and the machine shows WARMING UP and goes into the startup preparation status. The settings of each mode will be shown after the startup preparation of the machine ends. The machine is then in the startup status.

It will go into the standby status if you press this switch again in the startup mode.

## 3. Power indicator/OPERATION

When the power switch is pressed in the standby status, this indicator flashes blue, indicating that the machine is in the startup preparation status. It lights up in blue steadily after a while, indicating that the machine is in the startup status. It goes out and the standby indicator lights up when you press the power switch again in the startup status.

# Names and Functions

## 4. Input toggle switch/INPUT

Select the input toggle switch on the back panel for the unbalanced input terminals LINE-1, LINE-2, LINE-3 and the balanced input terminals BAL LINE-1, BAL LINE-2, BAL LINE-3.

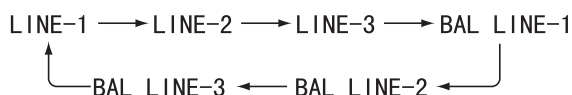

- When turned right, it switches in the order LINE-1 → LINE-2 → LINE-3 → BAL LINE-1 → BAL LINE-2 → BAL LINE-3 → LINE-1.....

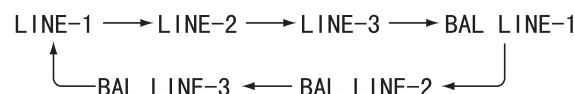

The machine is set to LINE-1 by the factory. The input/output muting circuit is activated during switching of the input sources and no sound is heard.

## 5. Input display/IN:

Display the currently selected input terminal.

- LINE-1: IN : LINE-1    ·    BAL LINE-1: IN : BAL.-1
- LINE-2: IN : LINE-2    ·    BAL LINE-2: IN : BAL.-2
- LINE-3: IN : LINE-3    ·    BAL LINE-3: IN : BAL.-3

## 6. Volume control knob/VOLUME

This control knob is used to adjust the volume output of the product. Turning this knob will increase or decrease the volume.

- Turn right: The volume increases by 1dB from Mute→-71dB → 0dB.
- Turn left: The volume decreases by 1dB from 0dB →-71dB →Mute.

The machine is set to mute by the factory

## 7. Volume display/VOL:

Display the current output volume by 1dB.

- -- Mute without sound
- -71dB: Min. volume; 0dB: Max volume

The machine is set to mute by the factory. -- is displayed when the power is turned on for the first time.

## 8. Output mode switch/output mode

The switch used to switch between unbalanced output, balanced output and bi-amp modes. When the switch is pressed, the mode changes in the order UNBAL → BAL → BI-AMP → UNBAL.....

- Unbalanced output/UNBAL : Music output from LINE-1 and LINE-2.
- Balanced output/BAL : Music output from BAL LINE-1 and BAL LINE-2.
- Bi-amp/BI-AMP : Music output from LINE-1 and LINE-2.

L ch LOW music output from LINE-1 L ch.

R ch LOW music output from LINE-1 R ch.

L ch HIGH music output from LINE-2 L ch .

R ch HIGH music output from LINE-2 R ch.

Switching to the bi-amp mode is not possible when the input toggle switch is in the balanced position.

Change the input toggle switch over to the unbalanced position and then switch the output mode.

The machine is set to unbalanced output (UNBAL) by the factory.

# Names and Functions

The input/output muting circuit is activated during switching of the output mode and no sound is heard.

Each output mode remembers its own default setting.

For more information about the default settings, refer to Hot to Set the Default Settings on Pages 16~20.

## 9. -Output mode- Non-balance indicator/- OUTPUT MODE - unbal

It lights up in blue to indicate that the current output terminals are unbalanced output terminals LINE-1 and LINE-2.

The machine is set to unbalanced output mode by the factory.

## 10.-Output mode-Balance indicator/- OUTPUT MODE - bal

It lights up in blue to indicate that the current output terminals are balanced output terminals BAL LINE-1 and BAL LINE-2.

## 11.-Output mode-Bi-amp indicator/- OUTPUT MODE - bi-amp

It lights up in blue to indicate that the current output terminals are un-balanced terminals LINE-1 and LINE-2 and both are currently in the bi-amp mode.

## 12.Balanced phase inversion switch/bal invert

This is the switch to adapt the balanced phase of the input device that connects to the product to the balanced phase of the product. Where inverting the balanced phase of the product is needed, press this switch to carry out the inversion. Whenever this switch is pressed, the balanced-phase changes in the order Normal→Invert→Normal.....

- The normal mode settings of the product 3PIN: +  
2PIN: -  
1PIN: GROUND
- Select the normal and invert modes according to the following table.

Input device phase	Output device phase	Product mode of the product	Phase setting of the product
BAL output: 3PIN +	BAL input: 3PIN +	BAL	Normal
BAL output: 2PIN +	BAL input: 2PIN +	BAL	Normal
BAL output: 3PIN +	BAL input: 2PIN +	BAL	Invert
BAL output: 2PIN +	BAL input: 3PIN +	BAL	Invert
BAL output: 3PIN +	UNBAL input	UNBAL	Normal
BAL output: 2PIN +	UNBAL input	UNBAL	Invert
UNBAL output	BAL input: 3PIN +	BAL	Normal
UNBAL output	BAL input: 2PIN +	BAL	Invert

The input/output circuit is activated during switching of the balanced phase and no sound is heard.

## 13.Balanced phase inversion indicator/ bal invert

It lights up in blue to indicate that the balanced input and output phases are inverted to the normal mode of the product.

The balanced phase is set to the normal mode by the factory.

## 14.Remote signal receiving section/remote

A receiver that receives the optical signal from the remote control is mounted in this section. Aim the signal transmission of the remote control at this section when you operate the remote control. The receiving section may not perform what the remote signal instructs if it is covered, so don't put anything around the receiving section.

# Names and Functions

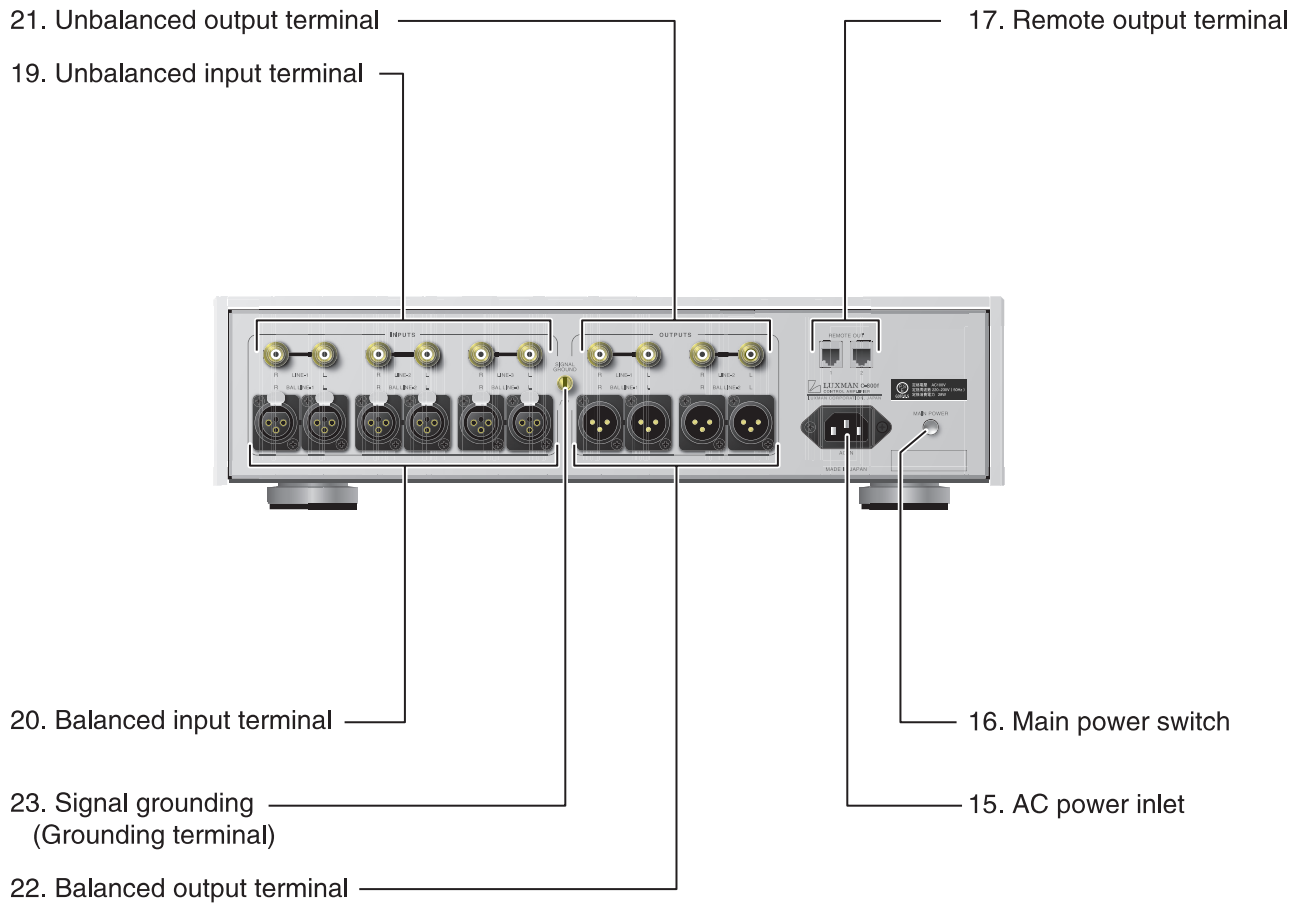



# Names and Functions



LUXMAN CORPORATION, JAPAN

## 15.AC power inlet/AC IN

Connect it to the attached power cable.  
Use AC 220V household socket.

## 16.Main power switch/MAIN POWER

This is the switch that changes the product over to the standby mode.

When the main power switch is turned ON, the standby indicator on the front panel lights up in yellow, indicating that the product is in the standby status.

When the main power switch is turned OFF, the standby indicator on the front panel goes out, indicating that the product is in the shutdown status.

## 17.Remote output terminal/REMOTE OUT

After the remote output terminal is connected to the remote input terminal on the power amplifier (M-800A etc.) using a special remote code, the power amplifier on the receiving end will be turned ON/OFF synchronously when the power switch of the product is turned ON/OFF.

The ON signal transmission from the remote output terminal delays over a short time after the power switch is pressed. Hence, the power amplifier on the receiving end will go into the startup status after a period of time equal to its mute time plus this delay.

The product has two built-in remote output terminals and can turn ON/OFF two power amplifiers simultaneously.

For information about setting the power amplifier on the receiving end, refer to the User Manual of the power amplifier on the receiving end.

## 18.Unbalanced input terminal/INPUTS (LINE-1, LINE-2, LINE-3)

This is the coaxial input terminal used for input of Line Level unbalanced music signals. Three systems – LINE-1, LINE-2 and LINE-3 – are available for the input.

Use an AV cable to connect the unbalanced output terminal of the CD player and other input devices.

For LINE-1, LINE-2 and LINE-3 music signal, the input toggle switch is used for selection of the music output.

The sound quality is same at LINE-1, LINE-2 and LINE-3. The user can connect the input terminal and device freely depending on personal preference.

## 19.Balanced input terminal/ INPUTS (BAL LINE-1, BAL LINE-2, BAL LINE-3)

This is the XLR input terminal used for input of Line Level balanced music signals. Three systems – BAL LINE-1, BAL LINE-2 and BAL LINE-3 – are available for the input.

Use a balanced cable to connect the balanced output terminal of the CD player and other input devices.

For BAL LINE-1, BAL LINE-2 and BAL LINE-3 music signal, the input toggle switch is used for selection of the music output.

The sound quality is same at BAL LINE-1, BAL LINE-2 and BAL LINE-3. The user can connect the input terminal and device freely depending on personal preference.

## Names and Functions

### 20. Unbalanced output terminal/OUTPUTS (LINE-1, LINE-2)

This is the coaxial output terminal used for output of unbalanced music signals from the product. Two systems – LINE-1 and LINE-2 – are available for the output.

Use an AV cable to connect the unbalanced input terminal of the power amplifier and other devices.

For LINE-1 and LINE-2 music signal, the output mode switch is used for selection of the music output.

Output mode	LINE-1 L ch	LINE-1 R ch	LINE-2 L ch	LINE-2 R ch
Unbalanced	L ch sound output	R ch sound output	L ch sound output	R ch sound output
Balanced	No sound	No sound	No sound	No sound
Bi-amp	L ch LOW sound output	R ch LOW sound output	L ch HIGH sound output	R ch HIGH sound output

The sound quality is same at LINE-1 and LINE-2. The user can connect the output terminal and device freely depending on personal preference.

The machine is set to unbalanced output mode by the factory.

### 21. Balanced output terminal/OUTPUTS (BAL LINE-1 and BAL LINE-2)

This is the XLR output terminal used for output of balanced music signal from the product.

Two systems – BAL LINE-1 and BAL LINE-2 – are available for the output.

Use a balanced cable to connect the balanced input terminal of the power amplifier and other devices.

Output mode	BAL LINE-1 L ch	BAL LINE-1 R ch	BAL LINE-2 L ch	BAL LINE-2 R ch
Unbalanced	No sound	No sound	No sound	No sound
Balanced	L ch sound output	R ch sound output	L ch sound output	R ch sound output
Bi-amp	No sound	No sound	No sound	No sound

The sound quality is same at BAL LINE-1 and BAL LINE-2. The user can connect the output terminal and device freely depending on personal preference.

The machine is set to unbalanced output mode by the factory.

### 22. Signal ground (ground terminal)/SIGNAL GROUND

This is the ground terminal of the machine that connects to the product.

It is used for reduction of the noise during the connection rather than safety.

# Names and Functions

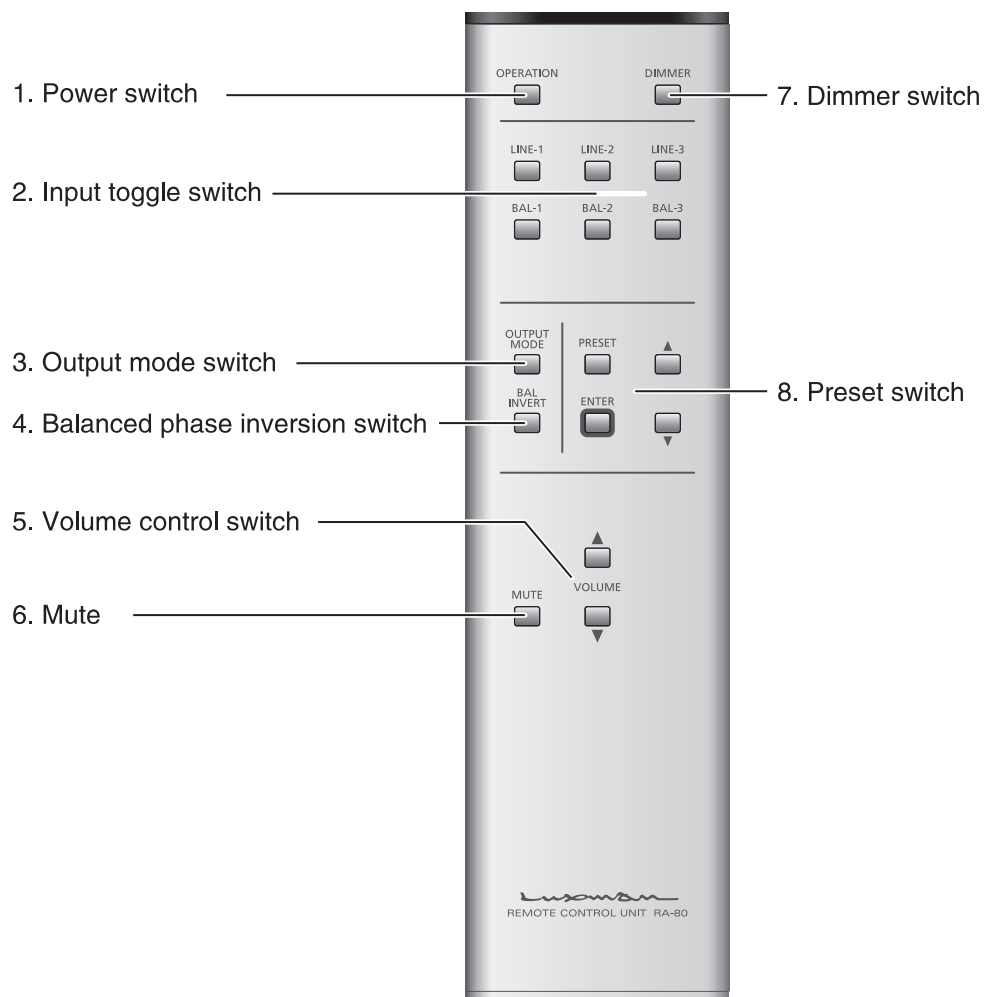

# Names and Functions

## 1. Power switch/OPERATION

When you press this switch in the standby mode, the standby indicator goes out and the power indicator flashes. Then the machine shows WARMING UP and goes in the startup preparation status. The power indicator lights up steadily after a while and the settings of each mode are shown on the machine, indicating that the machine is in the startup status. It will go into the standby status if you press this switch again in the startup mode.

WARMING UP

## 2. Input toggle switch/LINE-1, LINE-2, LINE-3, BAL-1, BAL-2, BAL-3

Select the input toggle switch on the back panel for the unbalanced input terminals LINE-1, LINE-2, LINE-3 and the balanced input terminals BAL LINE-1, BAL LINE-2, BAL LINE-3.

- Press LINE-1 to select LINE-1.
- Press LINE-2 to select LINE-2.
- Press LINE-3 to select LINE-3.
- Press BAL-1 to select BAL LINE-1.
- Press BAL-2 to select BAL LINE-2.
- Press BAL-3 to select BAL LINE-3.

IN : LINE-1  
VOL : -71dB

IN : BAL.-1  
VOL : -71dB

The input/output muting circuit is activated during switching of the input sources and no sound is heard.

## 3. Output mode switch/OUTPUT MODE

The switch used to switch between unbalanced output, balanced output and bi-amp modes.

When the switch is pressed, the mode changes in the order of: UNBAL → BAL → BI-AMP → UNBAL.....

- Unbalanced output/UNBAL  
Music output from unbalanced LINE-1 and LINE-2.
- Balanced output/BAL  
Music output from balanced BAL LINE-1 and BAL LINE-2.
- Bi-amp/BI-AMP  
Music output from unbalanced LINE-1 and LINE-2.  
Lch LOW music output from LINE-1 Lch.  
Rch LOW music output from LINE-1 Rch.  
Lch HIGH music output from LINE-2 Lch  
Rch HIGH music output from LINE-2 Rch.

Switching to the bi-amp mode is not possible when the input toggle switch is in the balanced position.

Change the input toggle switch over to the unbalanced position and then switch the output mode.

The machine is set to unbalanced output (UNBAL) by the factory.

The input/output muting circuit is activated during switching of the output mode and no sound is heard.

Each output mode remembers its own default setting.

## 4. Balanced phase inversion switch/BAL INVERT

When using the product, the balanced phase of the input device that connects to the product must be adapted to the balanced phase of the product.

Where inverting the balanced phase of the product is needed, press this switch to carry out the inversion.

Whenever this switch is pressed, the balanced-phase changes in the order Normal→Invert→Normal.....

# Names and Functions

- The normal mode settings of the product      3PIN: +  
2PIN:  
1PIN: GROUND

- Select the normal and invert modes according to the following table.

Input device phase	Output device phase	Product mode of the product	Phase setting of the product
BAL input: 3PIN +	BAL output: 3PIN +	BAL	Normal
BAL input: 2PIN +	BAL output: 2PIN +	BAL	Normal
BAL input: 2PIN +	BAL output: 3PIN +	BAL	Invert
BAL input: 3PIN +	BAL output: 2PIN +	BAL	Invert
UNBAL input	BAL output: 3PIN +	UNBAL	Normal
UNBAL input	BAL output: 2PIN +	UNBAL	Invert
BAL input: 3PIN +	UNBAL output	BAL	Normal
BAL input: 2PIN +	UNBAL output	BAL	Invert

The input/output muting circuit is activated during switching of the balanced phase and no sound is heard.

## 5. Volume control/VOLUME

These are the switches for adjustment of the volume output.

Pressing these switches will increase or decrease the volume of the product.

- Press ▲: The volume increases by 1dB in the order Mute → -71dB → 0dB.
- Press ▼: The volume decreases by 1dB in the order 0dB → -71dB → Mute.
- Press and hold ▲ or ▼ can adjust the volume rapidly. When you press and hold either switch, the volume
  - between -71dB and -36dB changes quickly, the volume between -36dB and -18dB changes a little slowly,
  - while the volume between -18dB and 0dB changes more slightly.
- The actual volume of each channel is the displayed value plus/minus the preset value.

```
IN: BAL.-1
VOL: 0dB
```

```
IN: BAL.-1
VOL: -71dB
```

```
IN: BAL.-1
VOL: --dB
```

The product will remember the volume at the time when the startup mode is switched to the standby mode. The memory will not be removed even when the main power switch of the product is turned off in the standby mode. However, the volume will be set to mute if the main power switch is turned off in the startup mode without first turning off the power switch.

## 6. Mute switch/MUTE

This switch is used to enter the mute mode with the current volume memorized temporarily. Music will be played with the original volume if you press this switch again in the mute mode. If the volume control is operated in the mute mode, the volume will change without leaving the mute mode.

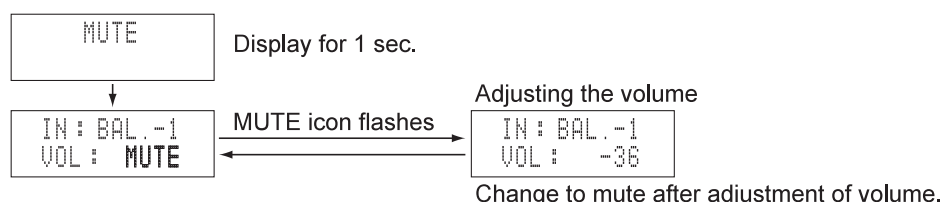

# Names and Functions

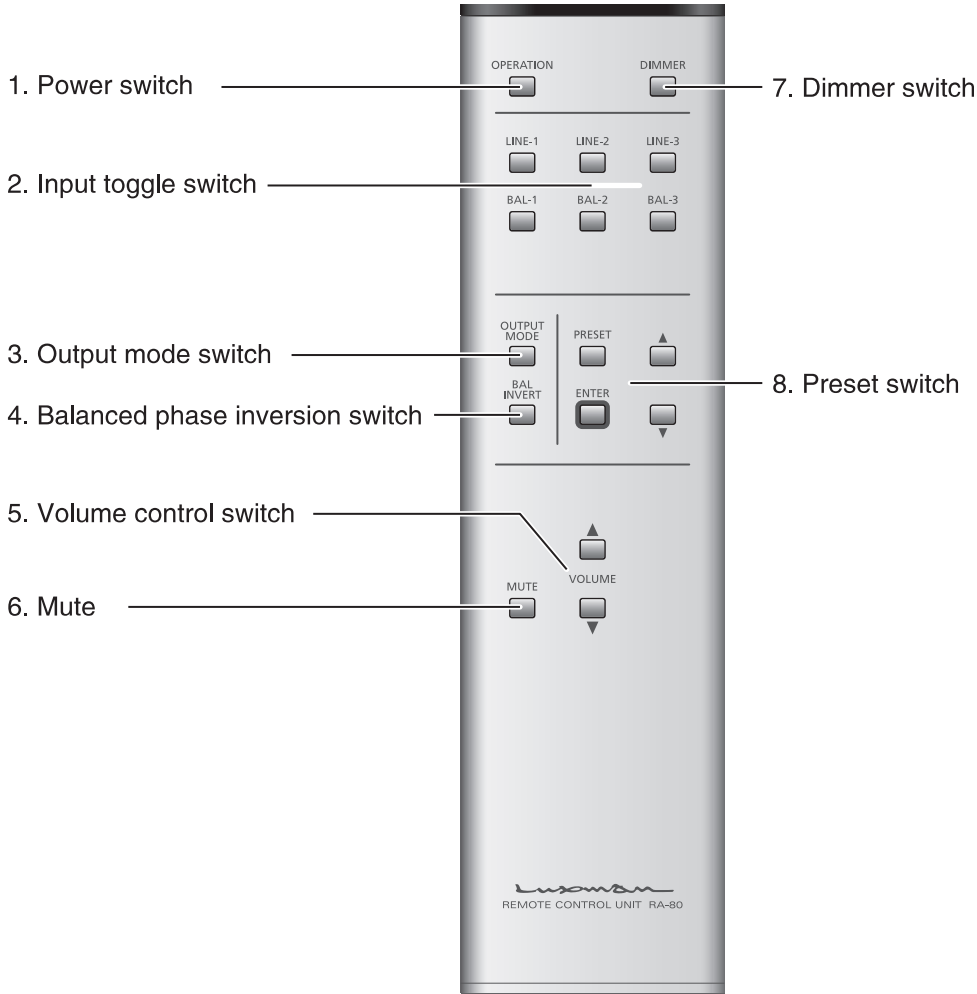

# Names and Functions



LUXMAN CORPORATION, JAPAN

## 7. Dimmer switch/DIMMER

This switch is used to adjust the brightness of the display and four steps from off to normal brightness are available for the adjustment.

Every time when you press the switch, the brightness will change in the order Normal→Slightly dark→Very dark→Off→Normal. When you turn off the display, it will go out 1 second after DISPLAY OFF appears.



Display for 1 sec.

This machine is set to normal mode by the factory.

## 8. Preset switches/PRESET

Press this switch to adjust the volume for each channel in different output modes.

Enter switch/ENTER

Press this switch to confirm the volume setting during the adjustment and move to the next channel.

▲ Switch/UP

▼ Switch/DOWN

Press either switch to change the volume during the adjustment.

- Unbalanced output/UNBAL

Adjust the left and right balance by setting L ch and R ch volume separately.

- Balanced output/BAL

Adjust the left and right balance by setting L ch and R ch volume separately.

- Bi-amp output/BI-AMP

BI-AMP and LR BALANCE adjustment modes are available and can be adjusted in order.

BI-AMP adjustment mode

Adjust L-HIGH (treble) ch and R-HIGH (treble) ch volume.

L-HIGH (treble) ch unbalanced output/LINE-2 L ch output.

R-HIGH (treble) ch unbalanced output/LINE-2 R ch output.

L-LOW (bass) ch and R-LOW (base) ch 0dB fixed.

L-LOW (base) ch unbalanced output/LINE-1 L ch output.

R-LOW (base) ch unbalanced output/LINE-1 R ch output.

LR BALANCE adjustment mode

Adjust the left and right balance by setting L ch and R ch volume separately.

## 9. Unbalanced output mode/UNBAL preset method

Balanced output mode/BAL preset method

- (1) Press the preset switch in the unbalanced or balanced output mode; the display will change to the status as the right figure shows in the first block and goes in the preset mode.

The L-CH volume icon starts flashing and the L ch volume can be adjusted.

- (2) Press ▲ to increase L ch volume by 1dB.

Press ▼ to decrease L ch volume by 1dB.

The volume can be adjusted in the range of ±6dB.

Ex.) Press ▼ once to display — 1dB as the right figure shows in the second block.

- (3) When you press Enter, the display will change to the status as the right figure shows in the third block.

## Names and Functions

The R-CH volume icon starts flashing and the R ch volume can be adjusted.

- (4) Press ▲ to increase R ch volume by 1dB.

Press ▼ to decrease R ch volume by 1dB.

The volume can be adjusted in the range of  $\pm 6$ dB.

Ex.) Press ▲ once to display +1dB as the right figure shows in the fourth block.

- (5) When you press ENTER now, the display returns to Step (1) and you can adjust the L ch volume again.  
(6) When you press the preset switch in any mode, the current setting will be memorized and you will quit the preset mode.

If no action is executed within 1 minute in the preset mode, you will quit the mode and return to the normal display with previous settings memorized.

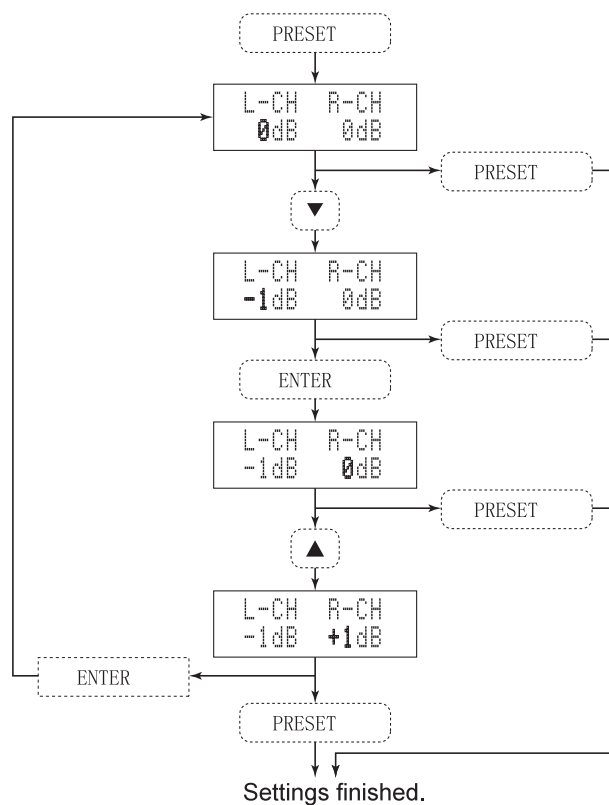



# Names and Functions



LUXMAN CORPORATION, JAPAN

## 10. Bi-amp output mode/BI-AMP by default

- (1) Press the PRESET switch in the bi-amp output mode and the display will change to the status as the right figure appears in the first block and go in the preset bi-amp mode.  
If there is no need to adjust L-Hi or R-Hi,  
press the preset switch again to move to the LR BALANCE adjustment mode.
- (2) When you press ENTER, the display changes to the status as the right figure appears in the second block. The L-Hi volume icon starts flashing and the L-Hi ch volume can be adjusted.
- (3) Press ▲ to increase L-Hi volume by 1dB.  
Press ▼ to decrease L-Hi volume by 1dB.  
The volume can be adjusted in the range of  $\pm 6$ dB.  
Ex.) Press ▼ once to display -1dB as the right figure shows in the third block.
- (4) When you press Enter, the display changes to the status as the right figure shows in the fourth block.  
The R-Hi volume icon starts flashing and the R-Hi ch volume can be adjusted.
- (5) Press ▲ to increase R-Hi volume by 1dB.  
Press ▼ to decrease R-Hi volume by 1dB.  
The volume can be adjusted in the range of  $\pm 6$ dB.  
Ex.) Press ▲ once to display +1dB as the right figure shows in the fifth block.
- (6) When you press Enter, the display returns to Step (2) and you can adjust the L-Hi ch volume again.
- (7) Pressing the preset switch in any one of the statuses (1)~(5) will move to the LR BALANCE adjustment mode.
- (8) When you press the preset switch after the preset bi-amp mode is adjusted, the display will change to the status as the right figure shows in the sixth block and move to the LR BALANCE adjustment mode.  
If there is no need to adjust LR BALANCE, press the preset switch again to quit the preset mode and return to the normal display.
- (9) When you press ENTER, the display will change to the status as the right figure shows in the seventh block.  
The L-CH volume icon starts flashing and the L ch volume can be adjusted.
- (10) Press ▲ to increase L ch volume by 1dB.  
Press ▼ to decrease L ch volume by 1dB.  
The volume can be adjusted in the range of  $\pm 6$ dB.  
Ex.) Press ▼ once to display -1dB as the right figure shows in the eighth block.
- (11) When you press Enter, the display will change to the status as the right figure shows in the ninth block.  
The R-CH volume icon starts flashing and the R ch volume can be adjusted.
- (12) Press ▲ to increase R ch volume by 1dB.  
Press ▼ to decrease R ch volume by 1dB.  
The volume can be adjusted in the range of  $\pm 6$ dB.  
Ex.) Press ▲ once to display +1dB as the right figure shows in the tenth block.
- (13) When you press ENTER, the display returns to Step (9) and you can adjust the L-ch volume again.
- (14) Pressing the preset switch in any one of the statuses (8)~(12) will quit the preset mode with the current settings memorized.  
If no action is executed within 1 minute in the preset mode, you will quit the mode and return to the normal display with previous settings memorized.

# Names and Functions

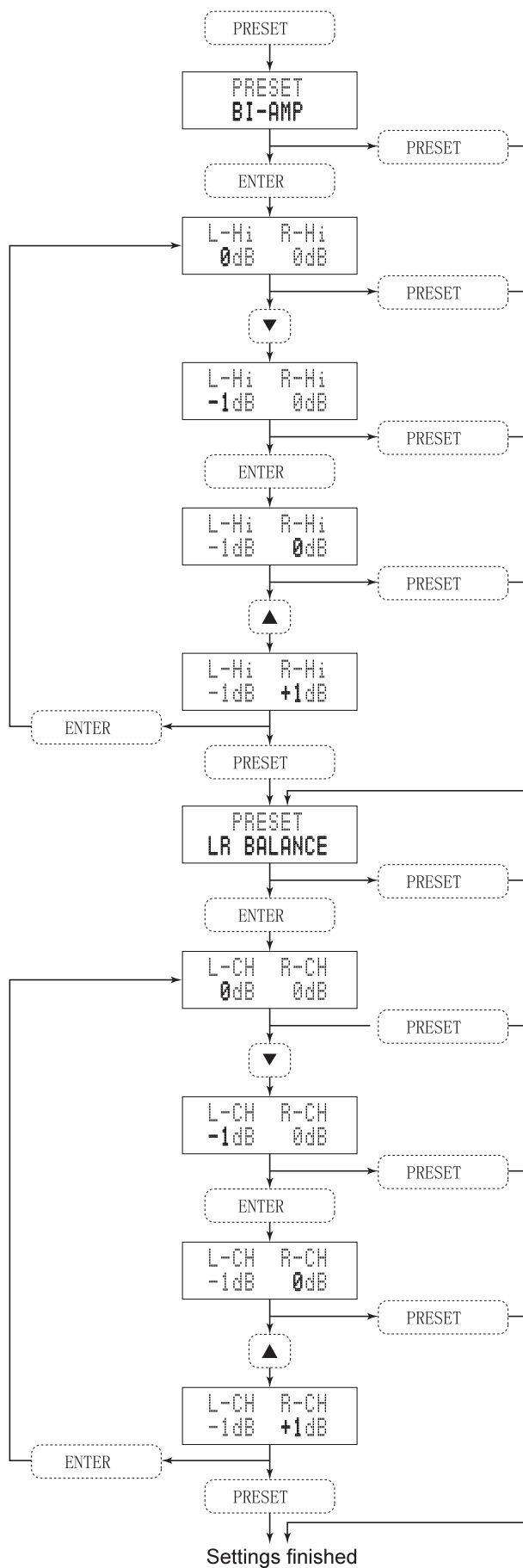

# Names and Functions

## 11. The memory function of settings

When the power is turned OFF, the last settings are memorized as follows.

Item Settings Example

INPUT	Last settings	LINE-1
OUTPUT MODE	Last settings	BALANCE
VOLUME	Last settings	-36dB
PRESET	Last settings of each item	L-CH -1dB, R-CH +1dB
BAL INVERT	Last settings	INVERT
DIMMER	Last settings	Darker

- The mute status is not an object of the memory and will be released automatically once the power supply is turned OFF.
- If the main power switch is switched OFF before the power switch is pressed, the volume settings will be set as mute and the settings besides the volume will be memorized.

## 12. Resetting

To reset all settings and changes to factory default, do the following:

- (1) Switch the product to standby.
- (2) Press and hold the power switch on the product for more than five seconds and then press Dimmer switch on the remote control without releasing the power switch.

The settings are reset to factory default.

Factory default settings:

Item	Settings
INPUT	LINE-1
OUTPUT MODE	UNBALANCE
VOLUME	--dB
PRESET	0dB
BAL INVERT	NORMAL
MUTE	OFF
DIMMER	MAX (maximum brightness)

## 13. Prohibition message and important notice

When changing the settings, some of them may not be changed. In this case, one of the following error messages will be displayed.

Current settings			Settings to be changed	Display	Important notice
OUTPUT MODE	PHASE	INPUT			
UNBALANCE	NORMAL	LINE-1,-2,-3	BAL INVERT	UNBALANCE MODE!!	Balanced phase cannot be inverted when unbalanced input/output is selected.
BI-AMP	NORMAL	LINE-1,-2,-3	INPUT SELECTOR BAL-1,-2,-3	BI-AMP MODE!!	Balanced input is not available in the bi-amp output mode.
BI-AMP	NORMAL	LINE-1,-2,-3	BAL INVERT	BI-AMP MODE!!	Balanced phase cannot be inverted in the bi-amp output mode.
UNBALANCE or BALANCE	NORMAL	LINE-1,-2,-3	OUTPUT MODE BI-AMP	IN: BAL.-* VOL:-**dB (Display unchanged)	Bi-amp output mode is not available in the balanced input status.

# Names and Functions

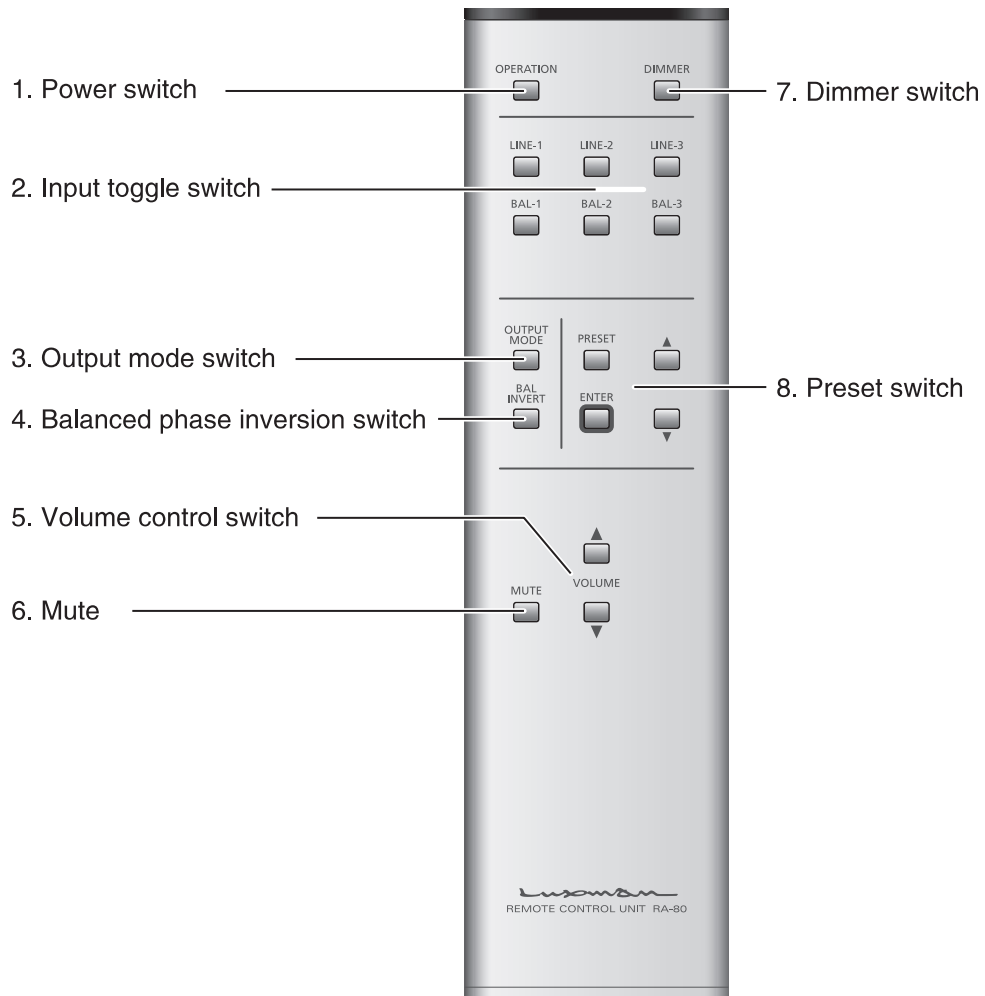

# How to Use Remote Control

When using the remote control, aim it at the receptor on the product within the range shown in the figure below.

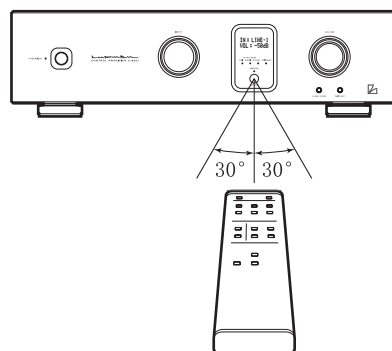

Effective range: about 5m

## Insertion of the battery

- (1) Remove the battery cover from the back of the remote control.  
Press the lock of the cover gently with your finger and push it downwards to remove the cover.
- (2) Insert two AAA batteries with the correct polarity as shown in the figure on the inner side of the cover.
- (3) Follow the opposite steps to push the cover from the bottom upwards until a click is heard.

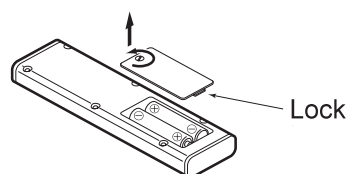

In case of low battery, the effective range may become shorter or the switch may not function. In this case, replace both batteries with new ones.

# Connections

Playing stereo normally

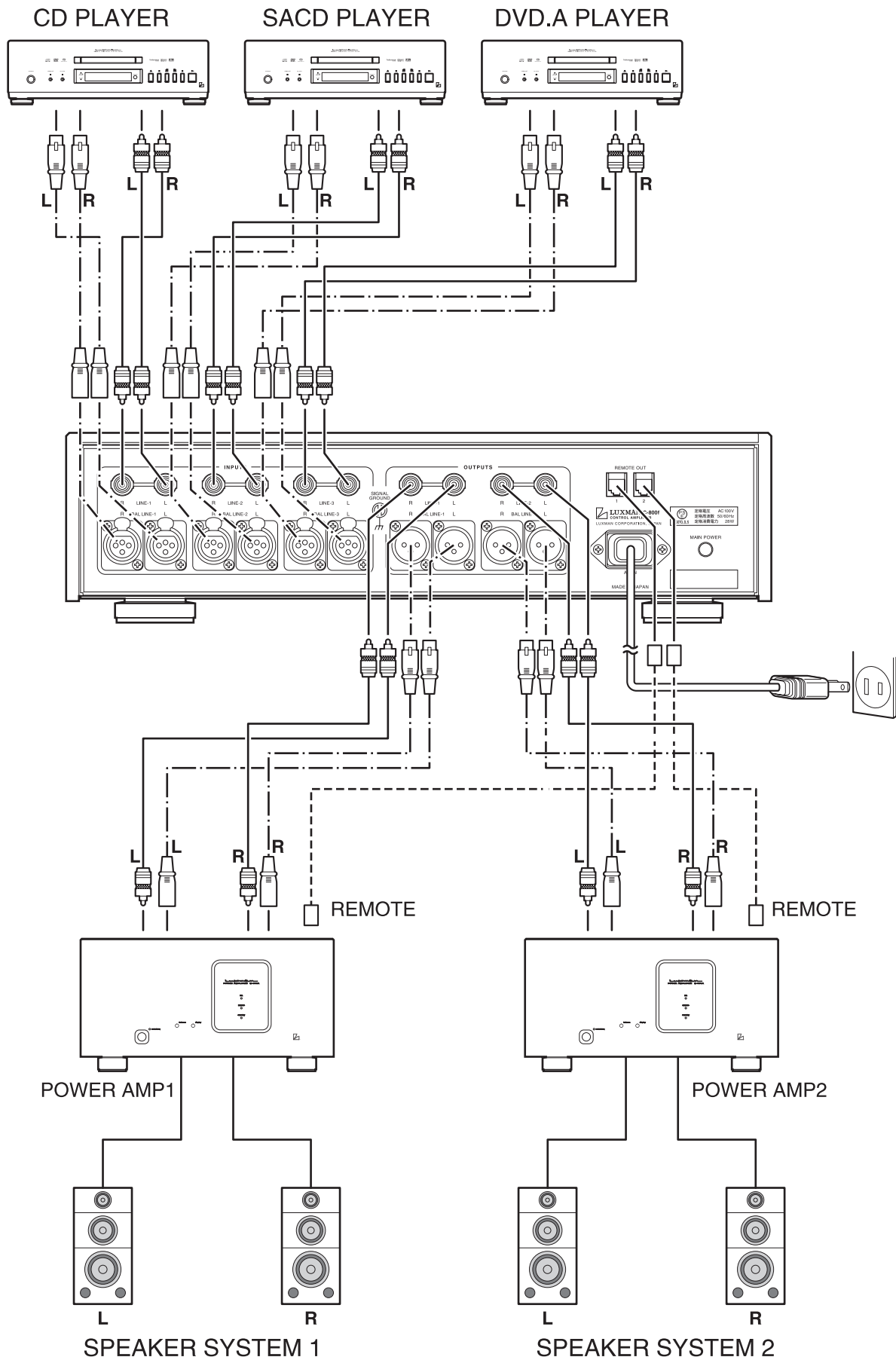

# Connections



LUXMAN CORPORATION, JAPAN

## Preparations before the connection

Before connecting to other devices, plug the attached power cable (3 holes) into the AC port of the product.

## Power connection

Connect the AC plug of the attached power cable to the AC220V socket in the audio room.

## Connection of the input terminal to the CD player or other input devices

Connect the output terminal of the CD player or other input devices to the input terminal of the product using an AV cable or balanced cable.

Note that the left and right channels should be connected appropriately. Reversed left and right channels will result in poor sound field positioning and the stereo will not play appropriately.

When an AV cable is used, low frequency noise will be produced due to loose grounding of the AV cable, if any, and result in S/N ratio attenuation. The plug should be connected appropriately to prevent this result.

The length of the connection cable is not important if the output impedance of the input device connected to the product is extremely low. However, if the connected input device has high output impedance, a shorter connection cable is suggested to prevent unnecessary treble attenuation.

## Connection of the input terminal of the power amplifier or other devices

Connect the input terminal of the power amplifier or other output devices to the terminal of the product using an AV cable or balanced cable.

Note that the left and right channels should be connected appropriately. Reversed left and right channels will result in poor sound field positioning and the stereo will not play appropriately.

When an AV cable is used, the low frequency noise will be produced due to the loose grounding of the AV cable, if any, and result in S/N ratio attenuation. The plug should be connected appropriately to avoid this result.

## Connecting the output terminal of the remote control to the power amplifier

The dedicated remote cable (non-polarized) attached to the power amplifier should be used to connect the input terminal of the power amplifier (e.g. Luxman M-800A) to the output terminal of the product.

This allows the power amplifier to be turned ON/OFF simultaneously when the product is turned ON/OFF.

There are two systems set for the remote output terminal and both output the same signal. Please choose what you prefer.

The dedicated remote cable should be used only for the connection of the Luxman preamplifier and power amplifier. Otherwise, the remote output circuit of the product may be short-circuited, resulting in malfunction.

To avoid damage to the amplifier and speaker due to excessive current input, turn OFF the main power switch or change the product to the standby mode and also turn OFF the power supply of the input/output device to be connected to the product before the connection. After the input/output device is connected, check the connection for its correctness before you turn on the product and the input/output device.

# Connections

Playing bi-amp/stereo

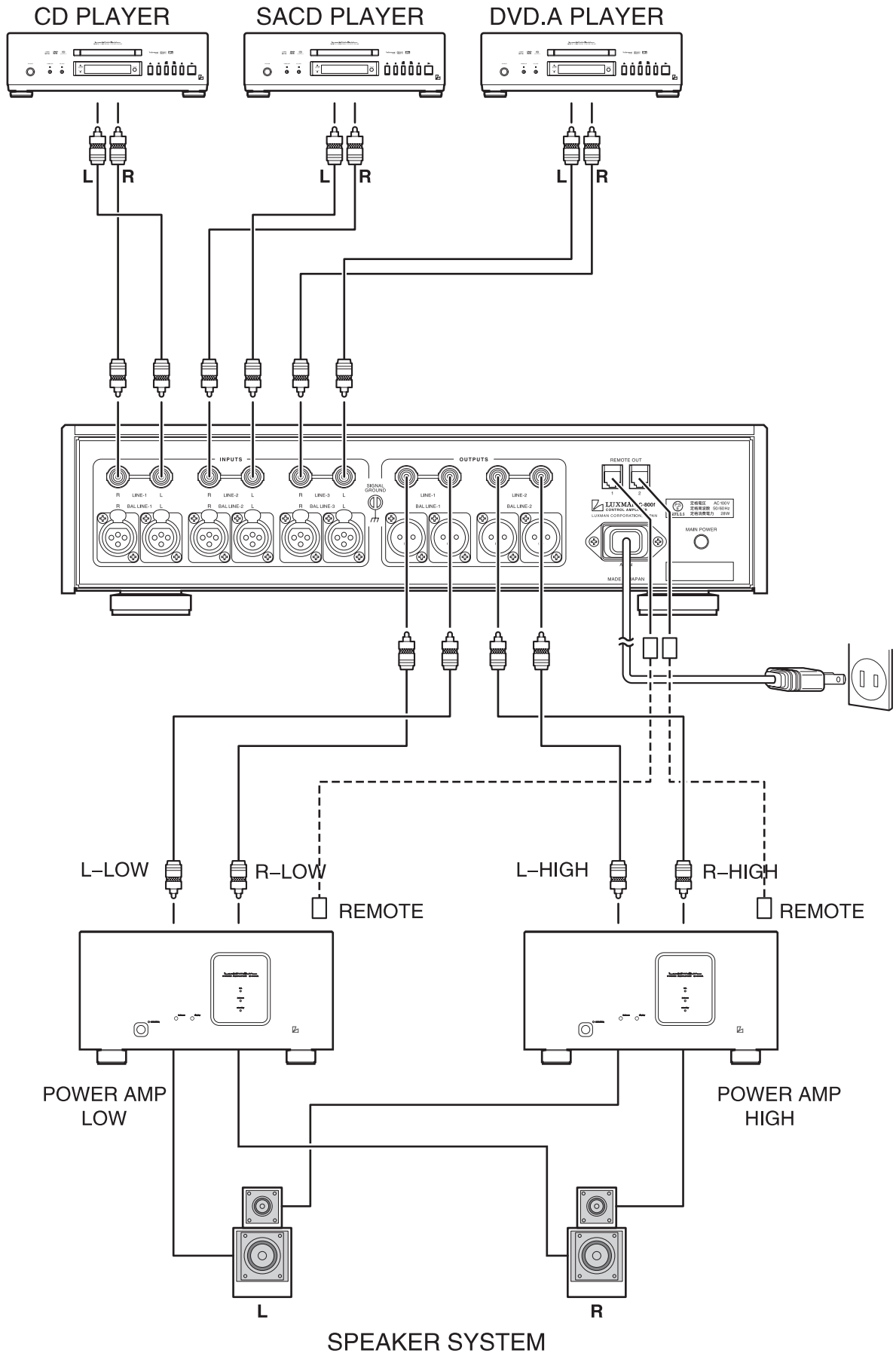





## Connecting the input terminal to the CD player or other input devices

When the product is used in the bi-amp output mode, only the unbalanced input terminal of the product works. In this case, there will be no sound output even if the balanced input terminal is connected.

Connect the unbalanced output terminal of the CD player or other input devices to the unbalanced input terminal of the product using an AV cable.

Note that the left and right channels should be connected appropriately. Reversed left and right channels will result in poor sound field positioning and the stereo will not be played appropriately.

When an AV cable is used, low frequency noise will be produced due to the loose grounding of the AV cable, if any, and result in S/N ratio attenuation. The plug should be CONNECTED appropriately to prevent this.

If the input device connected to the product has low output impedance, the length of the cable is not important. However, if the connected input device has high output impedance, a shorter connecting cable is suggested to avoid unnecessary attenuation of the treble.

## Connecting the output terminal to the power amplifier or other output devices

When the product is used in the bi-amp output mode, only the unbalanced output terminal of the product works. In this case, there will be no sound output even if the balanced output terminal is connected.

Connect the unbalanced input terminal of the power amplifier or other output devices to the unbalanced output terminal of the product using an AV cable.

Note that the left and right channels should be connected appropriately. Reversed left and right channels will result in poor sound field positioning and the stereo will not be played appropriately.

When an AV cable is used, low frequency noise will be produced due to the loose grounding of the AV cable, if any, and result in S/N ratio attenuation. The plug should be connected appropriately to prevent this.

The unbalanced LINE-1 L terminal outputs L ch bass while the unbalanced LINE-2 L terminal outputs Lch treble. The unbalanced LINE-1 R terminal outputs R ch bass while the unbalanced LINE-2 R terminal outputs Rch treble.

For the LINE-2 L and R treble terminals output the treble of L channel and R channel, the volume can be adjusted within  $\pm 6$ dB by the preset operation of the remote control in 1dB step.

## Connecting the output terminal of the remote control to the power amplifier

The dedicated remote cable (non-polarized) attached to the power amplifier should be used to connect the input terminal of the power amplifier (e.g. Luxman M-800A) to the output terminal of the product.

This allows the power amplifier to be turned ON/OFF simultaneously when the product is turned on or off.

When the mono power amplifier (e.g. B-1000f) is used, connect the remote output terminals 1 and 2 (two systems) of the product to one of the L ch remote input terminals and one of the R ch remote input terminals, respectively, on the power amplifier. Then connect the remote output terminal of the power amplifier that is connected to the remote output terminal of the product with corresponding channels to the remote input terminal of another power amplifier.

There are 2 systems set for the remote output terminal and both output the same signal. Please choose what you prefer.

The dedicated remote cable should be used only for the connection of the Luxman preamplifier and power amplifier. Otherwise, the remote output circuit of the product may be short-circuited, resulting in malfunction.

To prevent damage to the amplifier and speaker due to excessive current input, turn OFF the main power switch or change the product to the standby mode and also turn OFF the power supply of the input/output device to be connected to the product before the connection. After the input/output device is connected, check the connection for its correctness before you turn on the product and the input/output device.

# C-800f Block Diagram

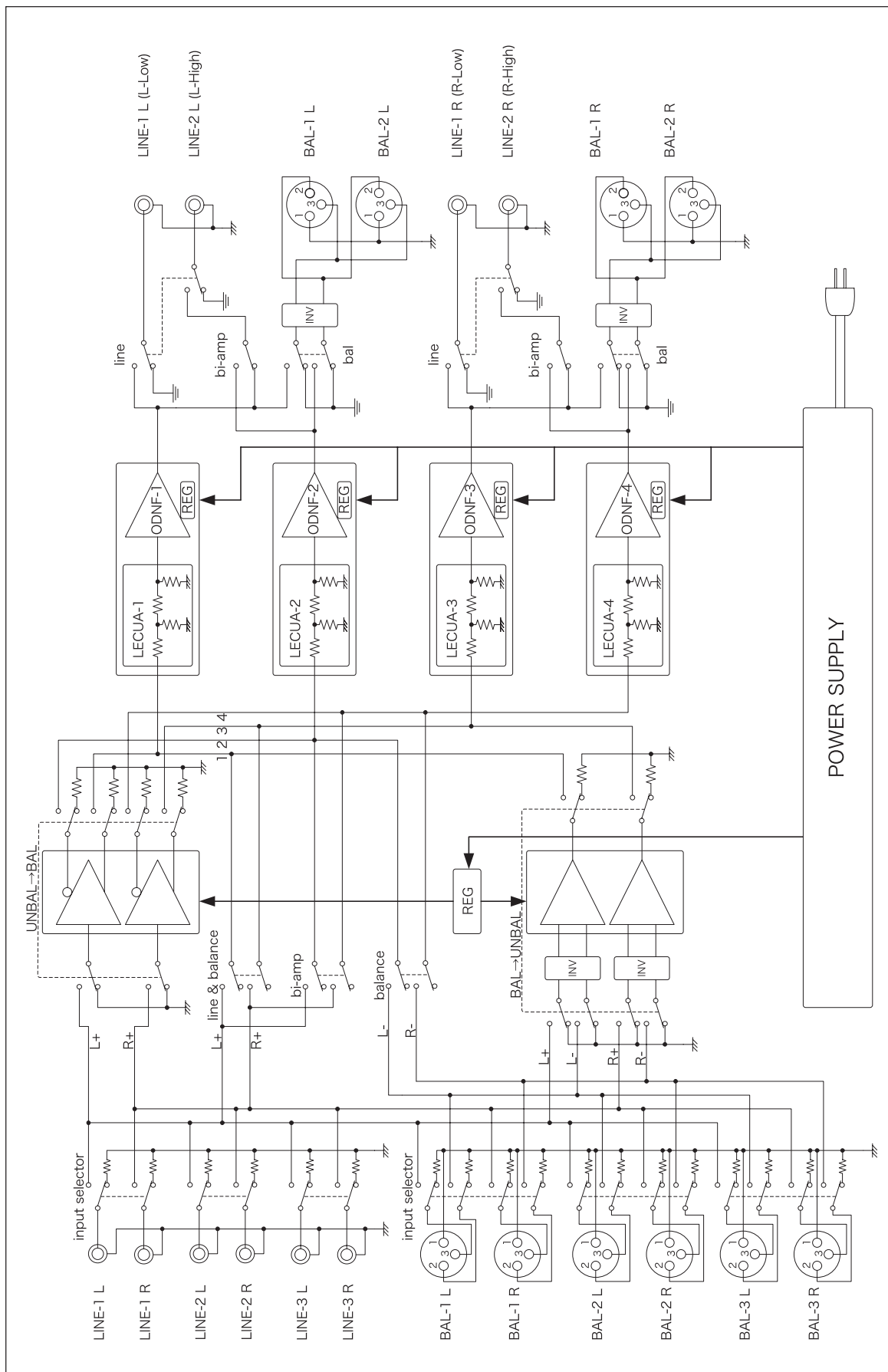

# C-800f Block Diagram

LECUA1000WN (ATTENUATOR + AMP) / EACH CHANNEL

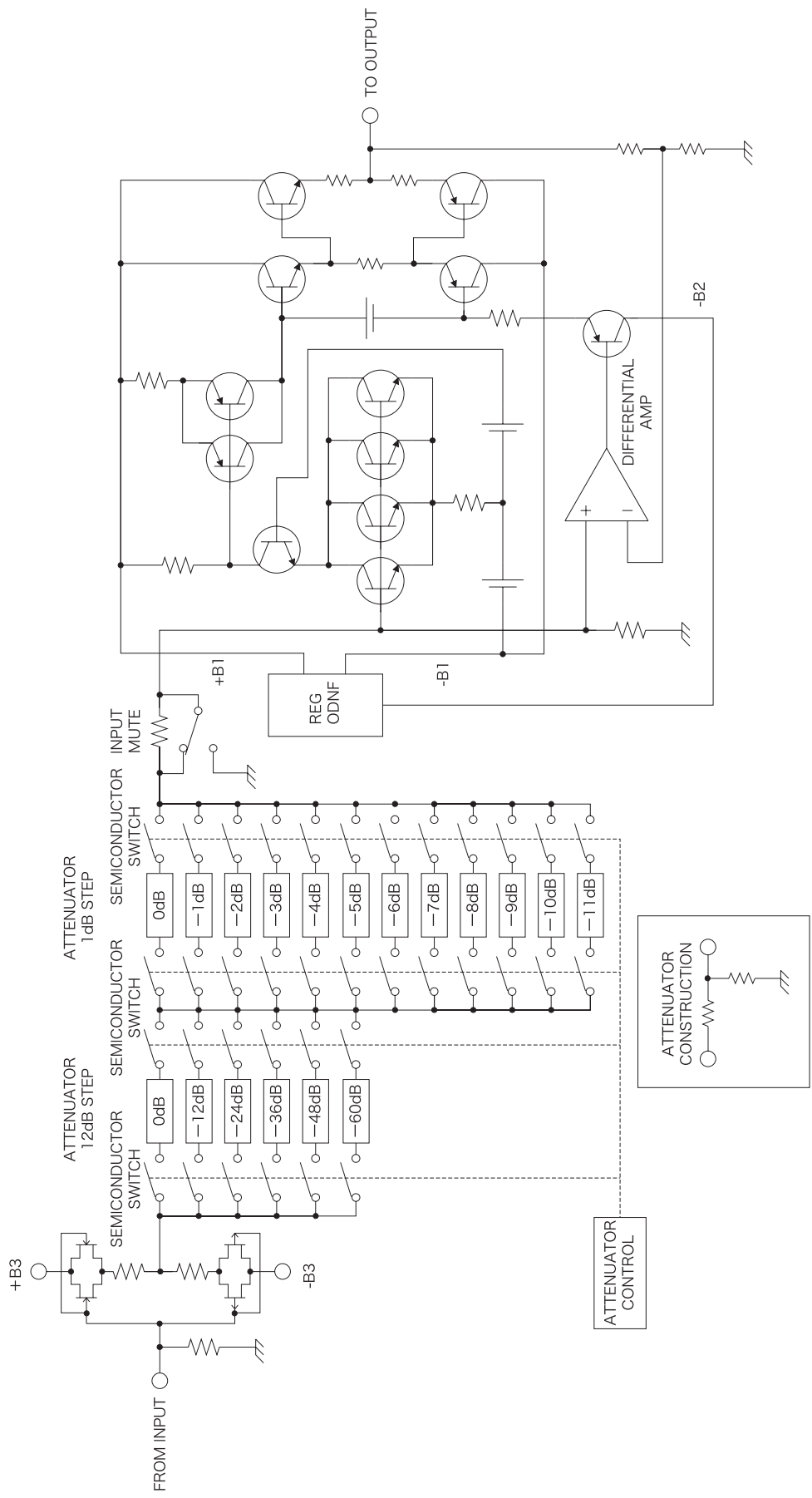

# C-800f Block Diagram

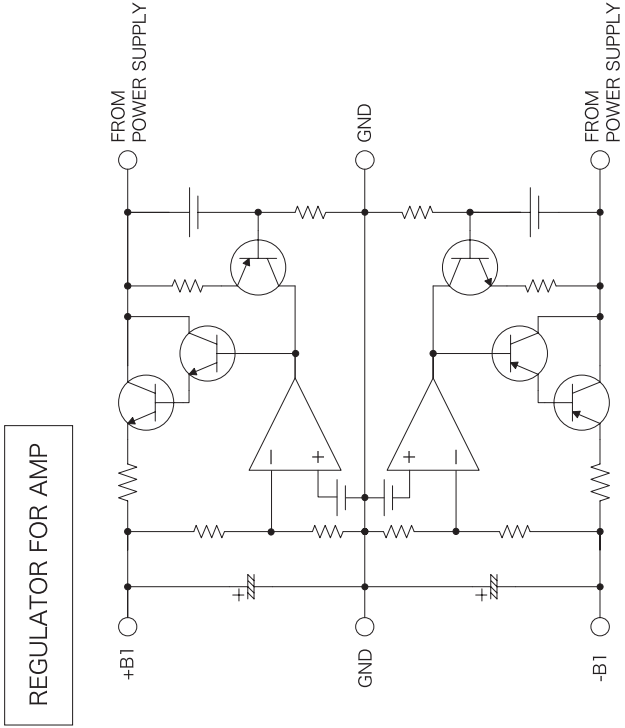
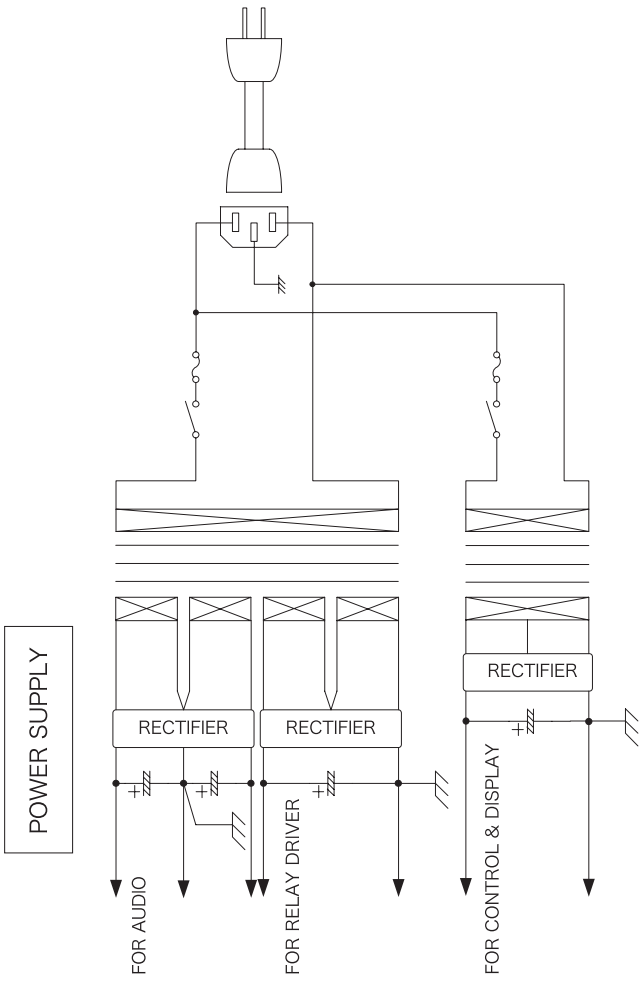

# Specifications



LUXMAN CORPORATION, JAPAN

Input sensitivity	LINE	300mV / 1V output • 1kHz • Load 50kΩ / GAIN 10.5 dB
	BAL LINE	300mV / 1V output • 1kHz • Load 100kΩ / GAIN 10.5 dB
	LINE → BAL LINE	305mV / 1V output • 1kHz • Load 100kΩ / GAIN 10.3 dB
	BAL LINE → LINE	305mV / 1V output • 1kHz • Load 50kΩ / GAIN 10.3 dB
Maximum output	LINE	5.5V / distortion 0.1% • 1kHz • Load 50kΩ
	BAL LINE	11V / distortion 0.1% • 1kHz • Load 100kΩ
	LINE → BAL LINE	11V / distortion 0.1% • 1kHz • Load 100kΩ
	BAL LINE → LINE	5.5V / distortion 0.1% • 1kHz • Load 50kΩ
Input impedance	LINE	47.5kΩ / 1kHz
	BAL LINE	95.0kΩ / 1kHz
	LINE → BAL LINE	33.5kΩ / 1kHz
	BAL LINE → LINE	100kΩ / 1kHz
	LINE not selected	33.5kΩ / 1kHz
	BAL LINE not selected	67.0kΩ / 1kHz
Output impedance	LINE	564Ω / 1kHz
	BAL LINE	1128Ω / 1kHz
Total harmonic distortion	LINE	0.009 % / 1 V output • 20Hz ~ 20kHz • Load 50kΩ
	BAL LINE	0.005 % / 1 V output • 20Hz ~ 20kHz • Load 100kΩ
	LINE → BAL LINE	0.009 % / 1 V output • 20Hz ~ 20kHz • Load 100kΩ
	BAL LINE → LINE	0.011 % / 1 V output • 20Hz ~ 20kHz • Load 50kΩ
Frequency response	LINE	+0, -0.1 dB/ 1 V output • 5Hz ~ 20kHz • Load 50kΩ
		+0, -3.0 dB/ 1 V output • 1Hz ~ 117kHz • Load 50kΩ
	BAL LINE	+0, -0.1 dB/ 1 V output • 5Hz ~ 20kHz • Load 100kΩ
		+0, -3.0 dB/ 1 V output • 1Hz ~ 114kHz • Load 100kΩ
	LINE → BAL LINE	+0, -0.2 dB/ 1 V output • 5Hz ~ 20kHz • Load 100kΩ
		+0, -3.0 dB/ 1 V output • 1Hz ~ 87kHz • Load 100kΩ
	BAL LINE → LINE	+0, -0.2 dB/ 1 V output • 5Hz ~ 20kHz • Load 50kΩ
		+0, -3.0 dB/ 1 V output • 1Hz ~ 84kHz • Load 50kΩ
S/N ratio	LINE	123dB (IHF-A) / distortion 0.1%, 1kHz, Load 50kΩ, -71dB noise
	BAL LINE	126dB (IHF-A) / distortion 0.1%, 1kHz, Load 100kΩ, -71dB noise
	LINE → BAL LINE	126dB (IHF-A) / distortion 0.1%, 1kHz, Load 100kΩ, -71dB noise
	BAL LINE → LINE	123dB (IHF-A) / distortion 0.1%, 1kHz, Load 50kΩ, -71dB noise
Accessories	Power cable Remote control RA-80 AAA battery × 2 Instruction manual Warranty card Safety instructions	
Power consumption	24W (according to the Electrical Appliance and Material Safety Law) 2.3W (standby)	
Power voltage	AC 220-230V ( 50Hz)	
Maximum dimensions	440 ( W ) × 117 ( H ) × 427 ( D ) mm	
Weight	17.6 kg	

※ The right is reserved to alter performance, specification, and appearance as required.

# Troubleshooting

While the unit is used, an unusual phenomenon may be confused as a malfunction for a certain reason. Prior to asking us for repair services, please check the table below and read the instruction manual for the subsidiary devices. If the cause of the malfunction cannot be identified, please contact your dealer.

Situation	Reason	Countermeasures
The power supply cannot be switched on after the main power switch is pressed. The standby indicator lamp does not light up.	<ul style="list-style-type: none"> <li>The plug of the power cable becomes loose at the AC socket or it is not inserted in the socket appropriately.</li> <li>The plug of the power cable becomes loose at the AC port of the product or it is not inserted in the port appropriately.</li> </ul>	<ul style="list-style-type: none"> <li>Insert the plug of the power cable into the AC socket appropriately.</li> <li>Insert the plug of the power cable into the AC port of the product appropriately.</li> </ul>
The power indicator lamp does not light up when the power switch is pressed.	<ul style="list-style-type: none"> <li>The main power switch is not switched on.</li> </ul>	<ul style="list-style-type: none"> <li>Switch ON the main power switch to light up the standby indicator lamp.</li> </ul>
The power has been switched on, the product is switching on and the power indicator lamp lights up in blue, but there is no sound.	<ul style="list-style-type: none"> <li>The connected input terminal does not consist with the selected input settings.</li> <li>The connected output terminal does not consist with the settings of the selected output mode.</li> <li>The connection is not appropriate.</li> <li>The volume control switch or the attenuator of the power amplifier is turned off.</li> <li>The mute is turned on.</li> </ul>	<ul style="list-style-type: none"> <li>Adjust the input settings to make the displayed input consist with the input terminal connected from the back panel or the input terminal port of the music player.</li> <li>Adjust the output mode to make the indicator lamps of the connected back panel output terminal and the output terminal of the music player light up.</li> <li>Perform the connection appropriately.</li> <li>Adjust the volume control switch or the attenuator of the power amplifier to obtain the required volume.</li> <li>Press the mute switch on the remote control to un-mute.</li> </ul>
There is sound output, but the volume is low. There is only mono output and the volume is low.	<ul style="list-style-type: none"> <li>The preset volume of both channels (or single channel) is 0.</li> <li>The attenuator of the power amplifier is turned ON.</li> </ul>	<ul style="list-style-type: none"> <li>Adjust the preset to obtain the required volume.</li> <li>Turn OFF the attenuator.</li> </ul>
Low frequency noise is heard. (humming or fizzing).	<ul style="list-style-type: none"> <li>The ground and the connecting cable are not connected.</li> <li>Induced noise produced from the power transformer of other machines is received.</li> <li>The input/output cable and the speaker cable are too close to the power cable.</li> <li>The power cable is used for grounding in the sound system.</li> </ul>	<ul style="list-style-type: none"> <li>Perform the connection appropriately.</li> <li>Set the product at a place far from other machines. Reconnect to the power socket port of a different system.</li> <li>Keep the input cable and the speaker cable away from the power cable.</li> <li>Attach a 3P → 2P adapter to the grounded power cable plug.</li> </ul>



LUXMAN CORPORATION, JAPAN





IAG House, Sovereign Court, Ermine Business Park, Huntingdon, Cambs, PE29 6XU, UK  
Tel: +44(0)1480 447700 Fax: +44(0)1480 431767 <http://www.luxman.co.jp>  
ラックスマン株式会社 〒222-0033 神奈川県横浜市港北区新横浜1-3-1  
tel.045-470-6991 fax.045-470-6997 [www.luxman.co.jp](http://www.luxman.co.jp)

IAG reserve the right to alter design and specification without notice. All rights reserved © IAG Group Ltd.  
Luxman is a member of the International Audio Group. CODE: LX12-MNL003a

