

SPECIFICATIONS

Circuiting system	SRPP, final stage cathode follower Non-feedback CR type equalizer
Vacuum tube used	ECC83 x 4 pieces, ECC82 x 2 pieces, and EZ81 x 1 piece
Input sensitivity (1kHz, When the gain is set to 36dB)	MM: 4mV MC: high 0.44mV, MC: low 0.18mV
Input impedance	MM: 30kΩ to 100kΩ (variable) MC: high 40Ω, MC: low 2.5Ω
Rated output/output impedance	250mV/850Ω
Gain (1kHz, When the gain is set to 36dB)	MM: 36dB MC: high 55dB, MC: low 63dB
Maximum allowable input (1kHz)	MM: 300mV, MC: high 34mV, MC: low 13mV
RIAA deviation	MM/MC high/MC low: 20Hz to 20kHz (±0.3dB)
Channel separation (10kHz)	65dB
Input	Unbalanced line x 3
Output	Unbalanced line x 2, Balanced line x 1
Power supply	230V~(50Hz) / 115V~(60Hz)
Power consumption	47W
External dimensions	440(W) x 92(H) x 397(D) mm front side knob of 5mm and rear side terminal of 12mm included in depth
Net weight	12.5kg (main unit)
Accessories	Power cable

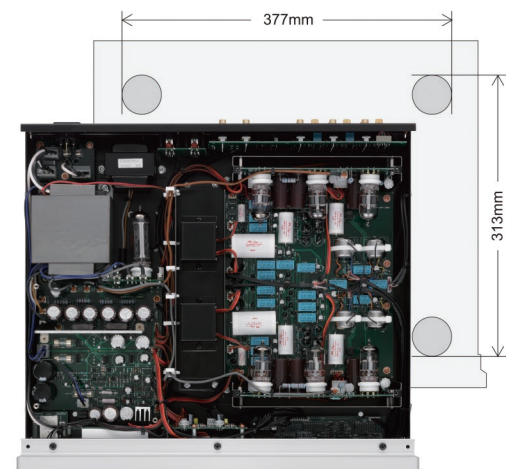
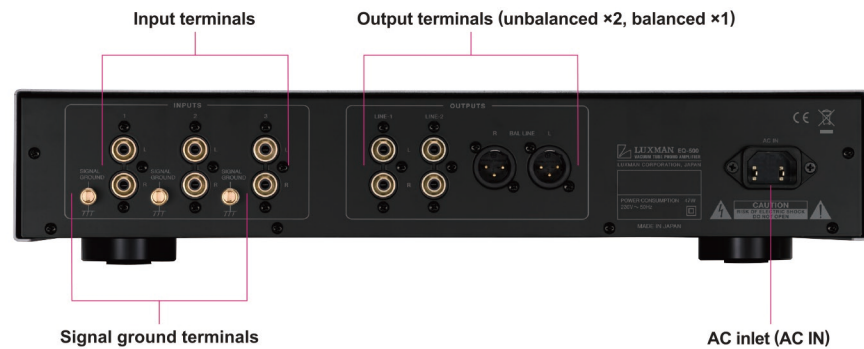

Internal configuration

*Rear panel : European Model

BELT DRIVE ANALOG PLAYER
PD-171A



* This product is supplied with a dust cover.
* The stylus light is detachable.
* No cartridge is included.

The PD-171A is a belt drive type analog player system that is based on the PD-171AL armless type and is equipped with a universal type tone arm, phono cable and headshell. The motor, drive circuit, bearing unit and other key components of the precursor model PD-171 that gave the unit its simplicity and fortitude have been improved further to achieve greater accuracy and stability in the PD-171A. Like the PD-171AL, by replacing tone arms you can enjoy the world of genuine analog reproduction to the full.

SPECIFICATIONS

<p>■ Turntable</p> <table border="1"> <tr> <td>Drive system</td> <td>Belt drive system</td> </tr> <tr> <td>Motor</td> <td>Reaction and AC synchronous motor Motor power supply: Quartz oscillation amplifier</td> </tr> <tr> <td>Material</td> <td>Machined aluminium plate, Surface finish: Diamond cut</td> </tr> <tr> <td>Rotation speed</td> <td>33 1/3 rpm, 45 rpm switch type, Rotation speed adjustment: ±5 %</td> </tr> <tr> <td>Wow and flutter</td> <td>0.04 % or less (W.R.M.S)</td> </tr> <tr> <td>Weight</td> <td>5.0 kg (platter)</td> </tr> </table>		Drive system	Belt drive system	Motor	Reaction and AC synchronous motor Motor power supply: Quartz oscillation amplifier	Material	Machined aluminium plate, Surface finish: Diamond cut	Rotation speed	33 1/3 rpm, 45 rpm switch type, Rotation speed adjustment: ±5 %	Wow and flutter	0.04 % or less (W.R.M.S)	Weight	5.0 kg (platter)	<table border="1"> <tr> <td>Bearing</td> <td>One point cross suspension</td> </tr> <tr> <td>Effective length</td> <td>229 mm</td> </tr> <tr> <td>Overhang</td> <td>15 mm, tracking error: +1.9° to -1.1°</td> </tr> <tr> <td>Applicable cartridge weight</td> <td>4 to 12 g (17 to 25 g headshell included)</td> </tr> <tr> <td>Adjustable height range</td> <td>38 to 60 mm</td> </tr> <tr> <td>Anti-skating</td> <td>0 to 3 g</td> </tr> </table>		Bearing	One point cross suspension	Effective length	229 mm	Overhang	15 mm, tracking error: +1.9° to -1.1°	Applicable cartridge weight	4 to 12 g (17 to 25 g headshell included)	Adjustable height range	38 to 60 mm	Anti-skating	0 to 3 g
Drive system	Belt drive system																										
Motor	Reaction and AC synchronous motor Motor power supply: Quartz oscillation amplifier																										
Material	Machined aluminium plate, Surface finish: Diamond cut																										
Rotation speed	33 1/3 rpm, 45 rpm switch type, Rotation speed adjustment: ±5 %																										
Wow and flutter	0.04 % or less (W.R.M.S)																										
Weight	5.0 kg (platter)																										
Bearing	One point cross suspension																										
Effective length	229 mm																										
Overhang	15 mm, tracking error: +1.9° to -1.1°																										
Applicable cartridge weight	4 to 12 g (17 to 25 g headshell included)																										
Adjustable height range	38 to 60 mm																										
Anti-skating	0 to 3 g																										
<p>■ Tone arm</p> <table border="1"> <tr> <td>Format</td> <td>Static balance, S-type</td> </tr> </table>		Format	Static balance, S-type	<p>■ Main unit</p> <table border="1"> <tr> <td>Power supply</td> <td>230V~(50Hz) / 115V~(60Hz)</td> </tr> <tr> <td>Power consumption</td> <td>38W</td> </tr> <tr> <td>External dimensions</td> <td>492(W) x 140(up to top surface of turntable) 195(at dust cover in use) (H) x 407(10 mm of rear fittings included) (D) mm</td> </tr> <tr> <td>Net weight</td> <td>25.4 kg(main unit)</td> </tr> </table>		Power supply	230V~(50Hz) / 115V~(60Hz)	Power consumption	38W	External dimensions	492(W) x 140(up to top surface of turntable) 195(at dust cover in use) (H) x 407(10 mm of rear fittings included) (D) mm	Net weight	25.4 kg(main unit)														
Format	Static balance, S-type																										
Power supply	230V~(50Hz) / 115V~(60Hz)																										
Power consumption	38W																										
External dimensions	492(W) x 140(up to top surface of turntable) 195(at dust cover in use) (H) x 407(10 mm of rear fittings included) (D) mm																										
Net weight	25.4 kg(main unit)																										

* The described company names and product names are trademarks or registered trademarks of each company.
* Specifications and appearance are subject to change without notice. * The products listed in this catalog do not include line cables. Please purchase cables separately.



Safety Cautions

To ensure correct use of this product, read the "Owner's Manual" prior to use. Failure to follow all safeguards can result in fire, electric shock, or other accidents.

A vacuum tube amplifier design that performs vinyl playback as you desire



RIAA-dedicated non-feedback CR type amplification circuit

All stages of the EQ-500 are vacuum tube. For the 1 and 2 stage a SRPP (Shunt Regulated Push-Pull) circuit is used which features low impedance, low distortion and prolongs the life of vacuum tubes. For the final stage a cathode follower parallel circuit is used with the ability to lower impedance further. The excellent sound quality of the CR circuit, supported by linear characteristics, is a direct result of the quality and accuracy of the parts used. LUXMAN has achieved the ultimate in high grade analog reproduction in the EQ-500 thanks to more than half a century of experience in manufacturing vacuum tube amplifiers and the selection of high performance parts. To protect minute analog signals from noise and magnetic field interference, the main sections of the EQ-500 are strongly shielded. The loopless chassis design of the EQ-500 isolates any ground impedance increase and magnetic field caused by the chassis current.



EQ-500 BLOCK DIAGRAM (AMP)

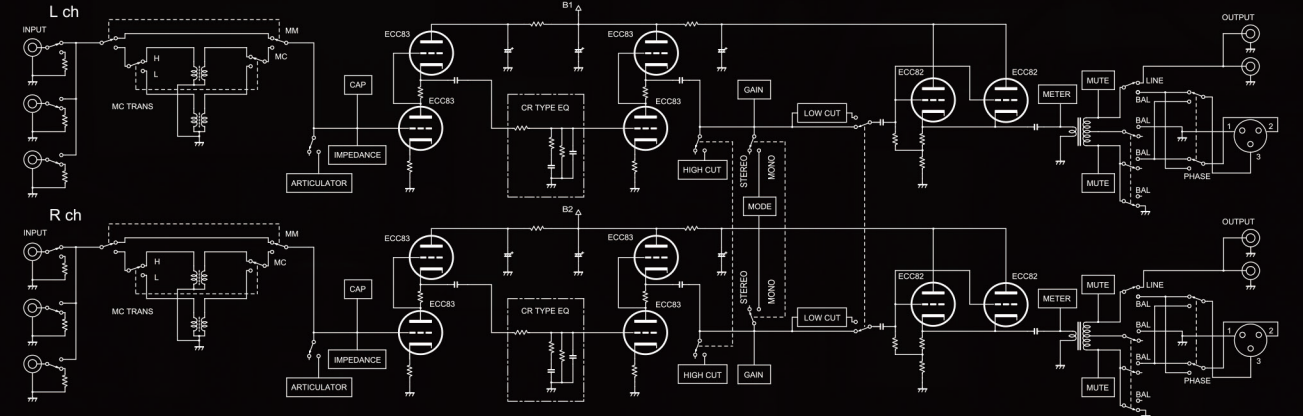

The joy of analog reproduction is the indulgence of the harmonic density and tonal character of vinyl playback, faithfully reproducing sound vibration and resonance inscribed on analog records without interruption.

The EQ-500 phono equalizer amplifier is a vacuum tube design for all stages to provide the ultimate experience in the expressive and colourful reproduction of music.

Fine adjustment and switching functions that are easily accessible on the elegant front panel allow you to enjoy the real pleasure of analog reproduction.

The debut of LUXMAN's masterpiece phono equalizer amplifier, the EQ-500, brings a new dimension that offers an extensive menu of the finest details of analog reproduction allowing you to recreate that ideal sound from your memory.



Stylish thin body with pointer type analog meters

The EQ-500 is housed in an elegantly thin chassis that can be mounted easily on a control amplifier. Stylish pointer type analog VU meters monitor the output levels and sit on the blaster white front panel alongside a variety of additional control switches to create the sound close to your taste.



Pointer type analog meter

Optimizing the cartridge load adjustment

The EQ-500 features a load capacity selection function from which 6 levels (0/50/100/150/200/300pF) can be selected according to the characteristics of the cartridge to be used. Combined with the load impedance selection function (30k to 100k ohms continuously variable) the original potential of the cartridge can be fully exploited.



2 kinds of load adjustment functions

Control functions

All main control functions can be operated from the front panel of the EQ-500; articulator function (cartridge demagnetizer), 3 position gain selection, unbalanced/balanced output selection, phase invert, monaural mode, low cut and high cut switches.

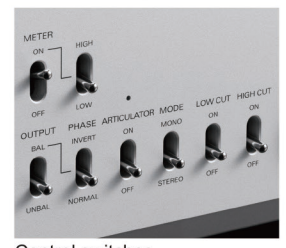

Control switches

An all-stage vacuum tube phono equalizer to suit diverse and specific tastes

The phono equalizer amplifier plays a unique role as part of an amplification system with respect to the characteristics and delicacy of signals. Because of this uniqueness, phono equalizers have been designed using various kinds of circuit methods and elements and have captivated the interest of enthusiasts for whom the detail of the sound is paramount. The EQ-500 is equipped with the circuit technology and musical essence inherent to its predecessor, the E-06 from LUXMAN. First launched in the 1980's, the E-06 is still a highly respected masterpiece of the CR type. This renowned circuit technology has been newly improved in the EQ-500 and uses vacuum tubes for all of the amplifier elements to bring the spirit of analog sound inscribed on the vinyl discs into life.

Vacuum tubes manufactured by JJ Electronic in Slovakia

The vacuum tubes specified for the EQ-500 are manufactured by JJ Electronic in Slovakia and have a reputation for high quality and superior performance. The characteristics of the gold plated ceramic tube sockets are ideal due to their solidity and low contact resistance. A stable voltage can be supplied to the amplification circuit using a rectifying tube and a choke coil.



Vacuum tubes and ceramic sockets

Large output transformer and 4 units of MC transformers

A large-capacity output transformer as well as MC step up transformers each playing a critical role in determining the sound quality and performance are made of super permalloy that particularly enhances the response to small signals. In addition, 4 units of MC step up transformers are mounted for MC-HIGH, MC-LOW, right and left independently.



Transformers

Original custom built parts

The coupling capacitors that have been chosen for the EQ-500 are manufactured by Mundorf in Germany, world renowned for their 'Audiophile' tenacious tonal quality. Original custom built components are abundant in the design of the EQ-500 ensuring the ultimate in sound quality and reliability for each circuit including OFC internal wiring.

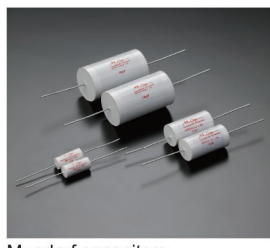

Mundorf capacitors

High-rigidity insulator

The high-rigidity insulator legs carved from solid block aluminium to suppress any vibration reaching the internal circuits of the EQ-500.



High-rigidity insulator leg