

LUXMAN

SUPER AUDIO CD PLAYER
D-08u

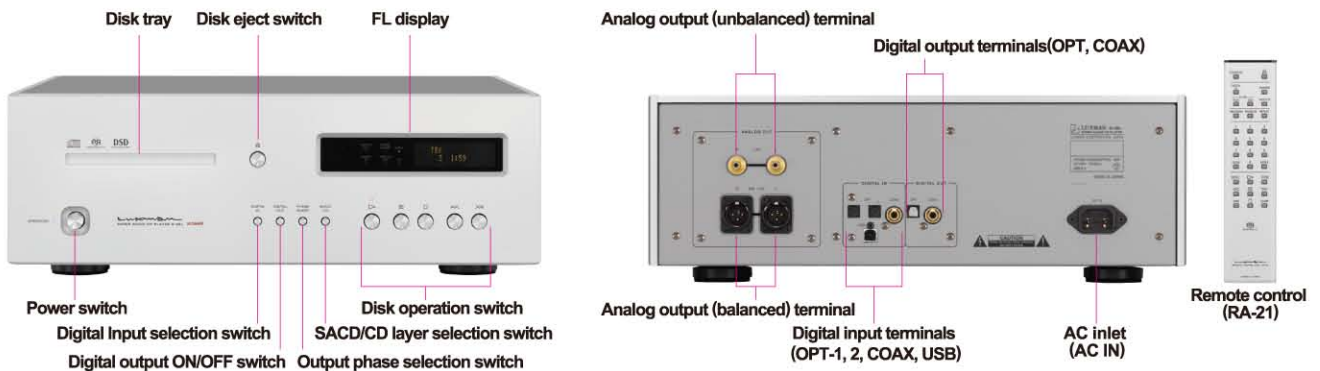

Top-end disk player, for enjoying a wide variety of sound sources



The flagship model of the CD/SACD compatible digital player, D-08u, is fully remodeled from D-08 released in 2008 and the digital and analog circuits of D-08 have been renewed. And now, our player is ready for USB connection with Windows and Mac PCs, which allows the user to reproduce file sound sources saved in PCs. LxDTM¹, Luxman's original overwhelmingly rigid disk drive mechanism, is provided as a disk media player to support stable rotation system, and the latest high sound quality configuration including 32-bit digital signal processor for the digital circuit is provided to suit to the PC audio era to which we have faced for years. What is more, the latest version 4.0 of ODNF² with fully balanced configuration, which is the core of Luxman's amplifier circuit technology, is used for the analog output circuit that determines the final quality of digital equipment, and the amount of materials and latest technologies, or important 3 elements to form a digital player, "Mechanism, Digital Circuit, and Analog Circuit" that are suitable for the flagship model are integrated. D-08u provides sound expression that arouses impression unimaginable by its quantitative specifications for from conventional CDs to the latest high resolution files in consideration of the future of the fast-changing sound source environment for audio systems. This product is Luxman's masterpiece that can be used and placed as the top of the lineup for a long time.

¹LxDTM is an abbreviation for LuXman original Disc Transport Mechanism. ²ODNF is an abbreviation for Only Distortion Negative Feedback.

■ Disk drive mechanism

- After consideration of ideal signal flow, oscillatory path, and weight balance, the high-rigid original disk drive mechanism, LxDTM, in which the left-sided mechanism layout is used is equipped.
- A box structure is introduced, i.e. extremely thick square pillars are used to solidly enclose the whole mechanism to rigidly cut out external vibration.
- The sealing type dust-proof shutter mechanism is integrated into the disk tray section of the front panel to enhance dust prevention and quiescence.

■ Digital circuit

- The USB input is ready for up to 384 kHz/32-bit PCM data and DSD data (2.82M, 5.64MHz). The S/PDIF input is ready for up to 192kHz/24-bit PCM signals.
- TAS3152, the latest 32-bit digital signal processor manufactured by Texas Instruments Incorporated, is introduced to upsample PCM signals to up to 384kHz.
- For PCM signals, 3types of sound qualities are switchable by the digital filter with 32-bit DSP, and for DSD signals, 2types of sound qualities are switchable by the DAC chip-embedded analog FIR filter.
- The low phase noise clock module with high precision and low jitter is equipped to reduce noise near the oscillating frequency.
- The jitter of USB signals is reduced by the dedicated DSP via asynchronous communication, the jitter of CD or S/PDIF signals is reduced by the embedded DAIR high-precision clock, and the jitter of SACD signals is reduced by the dedicated jitter reduction chip.
- Dual-configured (monaural mode) PCM1792A manufactured by Texas Instruments Incorporated is used for the DA converter, which has achieved ultra-high S/N ratio and dynamic range (theoretical value:132dB).



■ Analog circuit

- Luxman's original feedback type ODNF circuit with the latest version 4.0 whose distortion characteristics at high frequencies have been remarkably improved is embedded in the output amplifier unit.
- In the output circuit, there is no independent filter block, but band processing is gradually (primary filter x 3 pieces) implemented in the ODNF circuit. Therefore, natural analog waveforms can be reproduced.
- Stable and high inertial power is supplied from the audio-specific power transformer to each circuit through the regulator and block capacitor with large capacity allocated for each circuit.

■ Structure

- This system has a complex structure consisting of a loopless chassis to eliminate increased ground impedance and the effect of generated magnetic field caused by chassis current and a shielded chassis to block digital noise.
- The RCA terminal made of copper alloy that features copper's conductivity and brass's hardness and high-grade XLR terminal manufactured by Neutrik are used.
- The gradation cast-iron legs are provided to protect tiny delicate sound signals from unwanted vibration.

■ Other items

- Luxman's original high sound quality audio playback software, LUXMAN Audio Player of the latest version that is compatible with Apple Lossless and AIFF format additionally is supplied (Win/Mac).
- This system has an FL display with the zoom and dimmer functions and a high level of visibility for various modes, which stands out against blasted white sophisticated finishing.
- Peel coat PCBs without resist that adversely affects sound quality are used for all of the audio boards.
- The slim type aluminium remote control equipped with a user-friendly numeric keypad is supplied.

SPECIFICATIONS

| | |
|-----------------------------------|---|
| Applicable disk | 2-channel SACD, CD |
| Supported sampling frequencies | USB input (PCM): 32k, 44.1k, 48k, 88.2k, 96k, 176.4k, 192k 352.8k, 384kHz (16, 24, 32bits) USB input (DSD): 2.82M, 5.64MHz (1bit) COAX/OPT input: 32k, 44.1k, 48k, 88.2k, 96k, 176.4k, 192kHz (16, 20, 24bits) |
| Analog output voltage / impedance | 2.5V/300Ω (unbalanced), 600Ω (balanced) |
| Frequency response | CD 5Hz to 20kHz (+0, -0.5dB) CD 5Hz to 50kHz (+0, -3.0dB) USB 2Hz to 50kHz (+0, -3.0dB) |
| Total harmonic distortion | CD 0.0015%, SACD 0.0011%, USB 0.0009% |
| S/N ratio (IHF-A) | CD 123dB, SACD 106dB, USB 123dB |
| Disk drive mechanism | LxDTM (with dust-proof shutter) |
| D/A converter | Burr-Brown-made PCM1792A (monaural mode) x 2 |
| Output amplifier circuit | Fully balanced discrete ODNF version 4.0 |
| Power consumption | 36W 1W (at standby) |
| Dimensions | 440(W) x 154(H) x 413(D) mm front side knob of 2mm and rear side terminal of 11mm included in depth |
| Net weight | 22.5kg |
| Accessories | Remote control (RD-21) Power cable Install software CD |

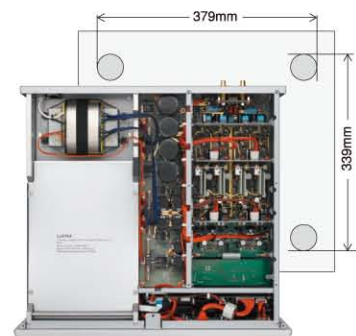

Internal configuration

* Windows is a registered trademark or a trademark of Microsoft Corporation in the United States and/or other countries.
* Mac is a registered trademark or a trademark of Apple Inc. in the U.S. and other countries. * DSD is a registered trademark.

LUXMAN

IAG House, 13/14 Glebe Road, Huntingdon, Cambridgeshire, PE29 7DL, UK
Tel: +44 (0) 1480 452561 Fax: +44 (0) 1480 413103 <http://www.luxman.com>

ラックスマン株式会社 〒222-0033 神奈川県横浜市港北区新横浜1-3-1
Tel.045-470-6991 Fax.045-470-6997 www.luxman.co.jp

IAG reserves the right to alter the design and specifications without notice. All rights reserved IAG Group Ltd.
Luxman is a member of the International Audio Group. Code: LN14-LL0002



⚠ Safety Cautions

To ensure correct use of this product, read the "Instruction Manual" prior to use. Failure to follow all safeguards can result in fire, electric shock, or other accidents.

*Design and specifications are subject to change without notice.